



Prairie Capital Corvair Association

P.O. Box 454
Pawnee, Illinois 62558

The Flat Six

April 2024

2024 Officers

President -Tim Mahler	(217) 793-3824	Vice-President Jim Allen	(309) 361-5351
Secretary-vacant	(Call Tim)	Treasurer-Glen Rittenhouse	(309) 472-3882
Membership-Chris Hall	(217) 691-6529	Historian/Inventory - vacant	
FlatSix Editor Tim Mahler	(217) 793-3824	Email	PrairieCapital@corvair.org

Board of Directors

Mike Hall (2024)	(217) 494-7105	Chris Hall (2024)	(217) 691-6529
Jim Collier (2024)	(217) 972-2285	Brian Nicholson (2025)	(217) 891-0808

From the Prez

Beware the ides of March. For me, that date came a week early when my brother's house caught on fire. As I write this, he is living in my spare room. Hopefully, we will find him his own place soon – or I may be admitted to the local looney bin. I am very accustomed to living alone.

It is nice outside for March - currently in the 70s. March weather is expected to return but than it will soon be April. I am ready for steady warmer weather. Spring flowers and classic cars running up and down the streets.

May will bring a return to the SMCC/PCCA Picnic. The clubs enjoyed this event for years at Lake Yaeger in Litchfield. For 2024, the two clubs will meet at the National Corvair Museum in Glenarm. I expect it to be a potluck type affair, details forthcoming. Dick Moon is in Kentucky so we will need to find an alternative to his famous homemade ice cream.

June will be a tour to Casey Illinois - near Moonshine Illinois where PCCA toured back in 2006. I'm working on the details – expect a visit to Arthur after Casey – excellent bakery and cheeses there.

The club may want to schedule a light Museum clean up day prior to the picnic (or maybe after?) Not so much for impressing our Show-me friends but just to help keep the place looking nice.



Shelby has been looking for different items to photograph. Picking the president's gavel for this one.

Happy Corvair-ing

Tim

Calendar of Events - 2024

PCCA Home Page may be found at <http://www.corvair.org/chapters/chapter627>



Directions to the CPF Corvair Museum near Glenarm Illinois. Take exit 88 from I-55, from either direction, head west – turn right if you are traveling south on I-55, left if traveling north. Follow the road as it curves to the left, south. Go straight at the stop light (turning right takes you to Chatham). The Museum is 1.3 miles from the stop light on the right hand side – just past the Double J campgrounds.

- April 5-6, 2024 Corvair Performance Workshop. Dernoshek Racing & Restoration 5645 Ashland Rd., Kannapolis NC 28083
- April 13, 2024 **PCCA Meeting 2:00-4:00 pm**
LOCATION: the CPF Museum in Glenarm
Refreshments: Glen and Rita Rittenhouse
- May 18, 2024 **Joint Picnic - SMCC and PCCA** at the National Corvair Museum.
Detatils to be announced later. If you have suggestions, let an Officer know.
- May 30,31, June1, 2024 the Pawnee Prairie day Show in Pawnee. Saturday June 1 typically has a car show
- June 22, 2024 **PCCA Tour to Casey Illinois.** Times, meeting location(s) to be determined (soon)
Will be a lunch stop – and a visit to a bakery in the afternoon (maybe ice cream too)
- July 11-14, 2024 DACC (Detroit) Homecoming - always a great event
Wyndham Garden Ann Arbor 2900 Jackson Road Ann Arbor, MI
- July 13, 2024 **PCCA Meeting Cancelled for July in favor of Homecoming and Convention**
- July 22-25, 2024 2024 CORSA International Convention
Marriott at the University of Dayton 1414 South Patterson Boulevard Dayton, Ohio
Hosted by Dayton Corvair Club, Corvair Club of Cincinnati, and Columbus Mid-Ohio
Vair Force **Concours, Road Rally, Economy Run, Autocross, swap meet, tech sessions, More** Call 1-937-223-1000 for room reservations.
- August 10, 2024 **PCCA Meeting 2:00-4:00 pm. LOCATION: the CPF Museum** in Glenarm
September 7, 2024 **SOS Auto Show, downtown Springfield 8:00am to 3:30pm**
PCCA Meeting 1:00pm. At the show.
- Sept 27-29 International RT 66 Mother Road Festival and Car Show. - Downtown Springfield
Friday night Cruise from Captial City Shopping to Downtown
Saturday - Main Car Show Day - Bands, Burn out contest, more
Registration - by 3-15 - \$35, by 4-15 - \$40, til 9-25 - \$45. On site \$55
- October 5, 2024 State Police Heritage Car Show
- October 12, 2024 **PCCA Meeting 2:00-4:00 pm. LOCATION: the CPF Museum** in Glenarm
- November 9, 2024 **PCCA Meeting 2:00-4:00 pm. LOCATION: the CPF Museum** in Glenarm
- December 14, 2024 **PCCA Christmas get together, luncheon.** Need location and ideas, please.

For more Corvair Events Check the calendar on the CORSA Web site: www.corvair.org

PCCA Meeting Photos

All Photos courtesy of Shelby Berta

Jim Collier's wonderful coup is back from the body shop. YEAH! Jim and Tim were the only two Corvairs driven to the March meeting, double the number for February. Wonder if we can double the number again for April? It's possible. The day was a bit nippy but not too bad for March. The wind was a tad strong - a front air dam really helps to keep the car in its own lane.



Jim and Beulah Collier's Maroon Coupe

The meeting itself didn't have a lot of surprises – not even for our birthday girl - Bernie. Daughter Carrie made chocolate cupcakes for refreshments and they were delicious. I refrained myself and only had one – then to save Jim from being required to eat all the leftovers, Jim Collier and I both took home another cupcake. Mine actually made it until Sunday.

A few changes were made to the PCCA Schedule – PLEASE take note: The May meeting has been moved back a week – so PCCA and SMCC can do a joint Picnic at the National Corvair museum. The exact details have not been made – but I suspect it to be a potluck type affair. Will need to work with someone to develop a couple “picnic” games – fan belt toss or some such.



Second big change was June – Moved to June 22, 2024 to do a Tour To Casey Illinois, Big Things in a Small Town. Also home to the Illinois Fastpitch Softball hall of fame. PCCA member Bill Pierson is inducted into that museum. Hopefully he will be able to attend - so we can get lots of pictures of him inside the museum.

Third (and last for now) Change is July – the CORSA International Convention is the following week and the DACC (Detroit) Homecoming is the same weekend as the July Meetin. A motion was made and approved to cancel the July PCCA meeting. I expect will be back at the Museum for August then September is the SOS Auto Show in downtown Springfield.



One final note – the RT66 International Mother road festival is September 28-29 in downtown Springfield. Friday night cruise from Capital City shopping center to downtown has been free in the past (a donation or registration may now be required but I didn't

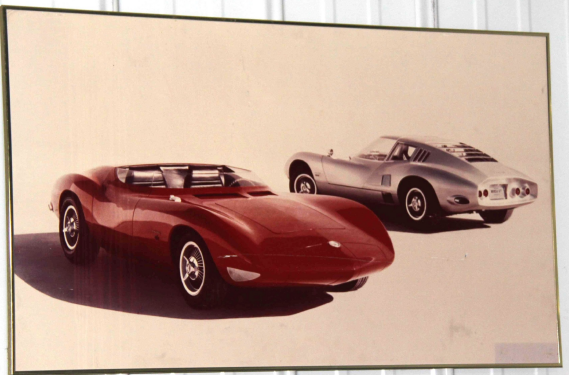

note that either way on their web site). The Show itself is expected to be filmed, in part, by Dennis Gage and his Classic Car show. The 1998 CORSA Convention was also on his show. Registration fees are listed in the Schedule and the web site. Not as expensive as I remembered – at least the registration fee hasn't not risen as much as some other shows.

Flash Backs

I found this on the CPF facebook page. An interesting ad placed by Huffy. The Corvair model I knew about. There is an example in the Corvair Museum (I took a picture, or thought I did, nope, didn't) I did not know about the Monza GT model. An enhanced version of the Corvair model. It has spring loaded racks for carrying books or something and an enhance "tank" on the main cross bar. The Corvair bike also came in 24 and 26 wheel sizes as well as "boys" and "girls" versions.



The Sinclair gas station ad was spotted on the "40mpg". It initially caught my attention because of the price per gallon. Those prices always remind me of the time my dad complained about "those gas prices are ridiculous" when we passed the local station who posted a price of 37 9/10.

I noticed the "gas war" sign after I pasted the image into the newsletter. I remember past PCCA meetings talking about those days.

National Corvair Museum News From PCCA member and CPF President Mike Hall

Hi all. I wanted to see if there is any interest in our membership helping at the museum on weekends so we can advertise to be open for tours. Brian and I are not always available so I wanted to reach out to see if anyone has an interest in helping us accommodate tours. As you know we are the only OPEN corvair museum in the country, and establishing hours other than by appointment will help us grow. Please let Brian or I know as soon as you can if you have interest in doing this. We will train you and provide you a script.

NOTE: At the February meeting, a Tuesday or Wednesday may also work in conjunction with the weekend. Suggested hours 10-4 – maybe 11-5. Trying to find days of week the Museum could advertise as open with the goal of drawing more visitors. Good Wi-Fi is available so a teenager helper may be encouraged to help as well.

In Memoriam. Sadly, just as I was getting ready to inform PCCA members about Dick and Neta’s new mailing address, Dick passed away. Prayers for Neta and Family. One of my favorite memories of Dick is a Corvair Display in Pekin where light rain fell sporadically. No sooner then Dick finished wiping off the rain drops, another short shower was soon to arrive. I think Dick finally surrendered. His home made ice cream was always a hit at the PCCA picnics in the Peoria/Pekin area. He will surely be missed.

Dick obituary follows:

NORTH PEKIN ~ Richard “Dick” Moon, 85, of Owensboro, Kentucky, passed away peacefully on Sunday, March 17, 2024 at his home. He was formerly of North Pekin. Born June 15, 1938 in Makanda to James Roy and Edna Moon. He was preceded in death by his parents and his step-daughter, Tina Geltz.

Those left to cherish his memory are his wife of 42 years. Oneta Moon; two sons, Andy (Maggie) Moon and Ronald Lamberson; two daughters, Karen Moon and Lori (Mike) Bayne; one step-daughter, Ronni (Don) Mitchell; one step-son, Steven Hebert; his son-in-law, Mike Geltz and an abundance of grandchildren and great-grandchildren.

Richard served in the United States Army in Ft. Still, Oklahoma.

He had worked at Caterpillar, Inc. in computer systems for 42 years before retiring.

Richard loved to travel in his retirement and was an avid photographer. He leaves a large collection of photos from his many vacation adventures with Neta. He loved Corvairs, Chryslers and antique cars. He was also a longtime member of the CORSA organization.

He followed Cat Racing in NASCAR and was a St. Louis Cardinals fan. Richard had a lifelong love of Pogo and also collected all things Pogo, including books and figurines.

His memorial service was Saturday, March 23, 2024 at Preston-Hanley Funeral Homes & Crematory in Pekin. Pastor Adam Penn officiated.

Memorial contributions may be given to a charity of the donor’s choice.



June 22, 2024 – PCCA Tour to Casey Illinois

And other points of interest. Lunch destination has not been determined, but we will stop for lunch (Oilfield and Moonshine are nearby). Casey is known for all kinds of “Big” things in a little town. Biggest rocking chair, Biggest Bat, Biggest mailbox etc. Also is the home of the Illinois Softball Hall of Fame - we will visit mainly because PCCA member Bill Pierson is inducted in that hall of fame. Yes, he is THAT good (or at least was, he’s a tad older now). Bill can detail a Corvair very well too. Times and other details will be available next month (if’n Tim gets his act together). Save the date (day tour)



Glen Rittenhouse follows “bringatrailer.com” results and has reported these over the last month. (6 total, 2 here 4 on page 8)



1961 Monza coupe \$7,100



1964 white Sedan (4 door) nice looking car. Bid to \$5,500

Mike Dawson always has good tips for us Corvair folk. I borrowed another one from from his archives on the HOACA website under tech articles. This number 180 and 181. Thanks Mike.

The Preventive Maintenance Series

Mike Dawson

Distributor Bushing Replacement (GM Only Supplied The Housing With Bushing Installed)

Many Corvair distributors go a lifetime needing only minor maintenance and sometimes breaker plate replacement. It has one upper bushing and the lower end of the shaft acts as a bearing within the rear housing, keeping the shaft running quite true. Two checks of the bushing while in the car would be to look at side play by trying to move the distributor cam across the shaft. If you note side play, be sure it is not between the cam and the shaft, which can wear if not lubricated. Another indication of a worn bushing is a small (or large) puddle of oil visible in the low part of the housing when you remove the breaker plate. Note: if you remove the distributor, it will appear to have bushing play if you move the bottom of the shaft against the bushing, so check it while installed. The up and down play (0.050) against the three piece thrust washer is also normal to allow the assembly to have running clearance with different housings and oil pumps.

If you determine you need a bushing, or are doing a complete distributor recondition, the following tips on bushing replacement may help.

Tools you will need include the following: #4 and #6 roll pin punches, a homemade tool for pushing out the old bushing, and a hone to size the new bushing as all bushings that I have purchased recently are slightly oversize (which is good). My pusher is a piece of 1/8" x 3/4" steel stock trimmed to fit between the ribs that surround the bushing. Also pictured is a homemade holding fixture for removing and installing pins, for which you can substitute a padded vice.

Pictured below is the minimum disassembly necessary to replace the bushing in a '62-'69 ('60-'61 will be similar). This would obviously be the time to also check and lube the advance mechanism.

File off any sharp edges at the two pin holes and polish the shaft before fitting the bushing. During reassembly remember the divet on the gear must align with the direction of the rotor notch.

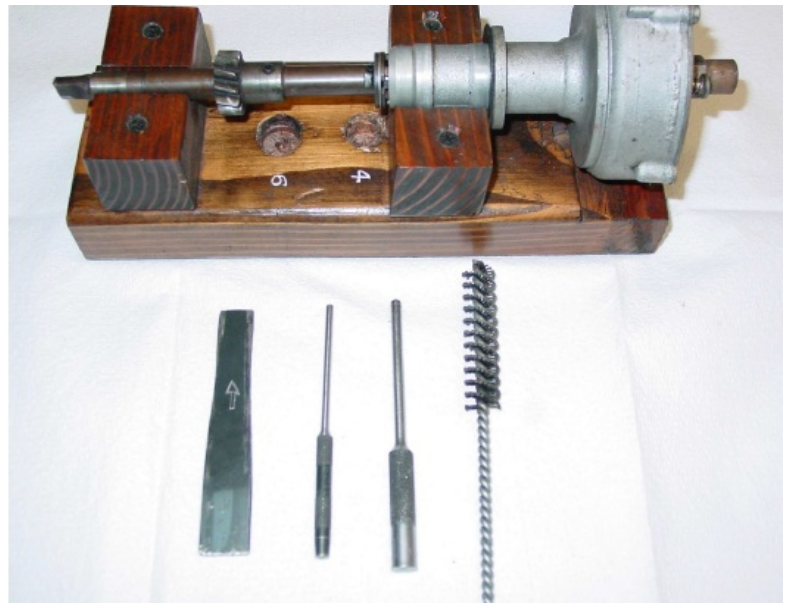

Manual Transmission Shifter Seal Leak

Leaks at the shifter seal can occur from the constant exposure to road grit at high speed or just from old age. The early design had a flange that made it easy to pry out of the case and along with the minimal loss of lube while changing the seal, it was not a major operation. All of the current seals available (4 different brand labels) are all the same design without the flange, which makes careful removal with an ice pick type tool, installation of a small sheet metal screw or similar removal method necessary. Care must be taken to avoid damage to the shaft or the cast iron case.

Installation of the new seal should include polishing the shaft while in 4th or 2nd gear (shaft out as far as possible) and use of one layer of Scotch tape overlapping the pin hole and the end of the shaft to aid in protecting the seal lips until completely installed. Even if you use fine sand paper or cloth to polish over the pin hole, the seal lips can drop into the hole and can be cut by a razor sharp edge at the hole chamfer. The tape eliminates the lips dropping into the hole area. And, as with any double lip seal, add grease in between the two lips before installing.

Note tape over the pin hole and end of shifter shaft:



CORSA INTERNATIONAL CONVENTION 2024

2024 CORSA International Convention - Dayton, OH

Hotel Booking is now open!

Monday July 22nd thru Thursday, July 25th.

Monday 7/22-

Welcome Party, Car Display and Valve Cover Racing!

Tuesday 7/23 - Concours d'Elegance during the day; Special evening event: "Dinner under the Wings" at the National Museum of the United States Air Force

Wednesday 7/24 - Econo Run and Road Rally

Thursday 7/25 - Autocross and Banquet

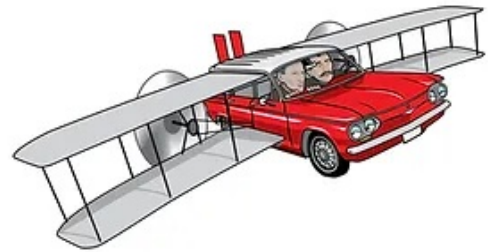

There is much more planned for your enjoyment and many local attractions to visit before and after the convention. More details on these attractions and information about the convention schedule will be updated to the CORSA site and published in the Communique. Convention Registration will open in March 2024.

Hotel information: (Call the 1-937-223-1000 number, the 1-800 doesn't have the right information)

Marriott at the University of Dayton 1414 South Patterson Boulevard Dayton, Ohio 45409 1-937-223-1000

Room rate is \$142 per night. Mention The Corvair Society of America 2024 for special room rate.

This rate is available for Sunday thru Friday night reservations.

Go to the CORSA Web site to find the link to the hotel reservations page www.Corvair.org

General Meeting Notes March 9, 2024

by Tim Mahler

President Tim Mahler called the meeting to order at 2:00pm opening with the Pledge of Allegiance. Jim and Beulah Collier and Tim were recognized for driving their Corvairs to the meeting. It was noted that it was good to see the Collier’s coupe is back from the body repair shop.

The secretary report for February was printed in the FlatSix, there was no changes noted to be made. Glen Rittenhouse gave the February treasury report.

Checking Account Beginning Balance	2/10/2024	\$ 4,261.43
Income - Dues deposited (10)		\$ 175.00
Expenses - None		\$ 0.00
Total Checking 03/09/2024		\$ 4,436.43
+ Savings Acct. Balance (required for a checking acct)		\$ 5.00
+ Total Cash on Hand 2/10/2024	\$125.13	
50/50 Winner - Bill Pierson	\$11.00	
Donations - J.Allen \$5.00 L. Jahn \$5.00	\$10.00	
Total Cash on Hand 3/9/2024		\$ 146.13

Total Checking/Savings/Cash March 09, 2024 \$ 4,587.56

The report was approved those present.

Membership report indicated that we had just 5 members yet to renew (the correct count is 6 members)

New Business - Tim reported that the PCCA Board had approved having a joint picnic with SMCC on May 18, 2024. This would be in lieu of a general meeting May 11. Picnic details to be announced later - Mike Hall initially made the proposal to SMCC at their February meeting.

Another change in the PCCA Schedule. Larry Jahn has been suggesting a tour to Casey Illinois home of “Big Things” and the Illinois Softball Hall of Fame. Tim is going to attempt to coordinate things. Moonshine vs Oil Field vs in town for Lunch was mentioned. PCCA has been to Moonshine before, so leaning elsewhere.

Final schedule item – July. The CORSA Convention the following week and the Detroit Homing the same weekend as the meeting. A motion was made cancel the July PCCA meeting by Joe Ori, 2nd by Glen. Motion carried.

Last item on the agenda – Bill Berta has noted that the RT66 Mother Road Festival would be a good place to get exposure for the Corvair (and museum). Dennis Gage (Classic Car show) is expected to be in attendance to film the event which increases the exposure. PCCA may need to consider subsidizing registration fee to increase our participation numbers. We did that back when the show first came to Springfield.

Meeting was adjourned at 2:49 pm. Refreshments provided by Jim and Bernie Allen (thank you Carrie for making wonderful cupcakes) - It was to honor Bernie Allen’s birthday. She’s a young person.

50/50 drawing was won by Jim Collier - might pay some of his gasoline bill for the day.



Glen Rittenhouse follows “bringatrailer.com” results and has reported these over the last month. (6 total)

1962 yellow cvt, tired interior, poor paint, rust \$6,400
1965 Corsa Turbo coupe \$26,500

1965 Monza coupe “project car” \$4,250
1964 Monza Cvt, 4sp, bare bones
No Sale at \$10,500



The Flat Six

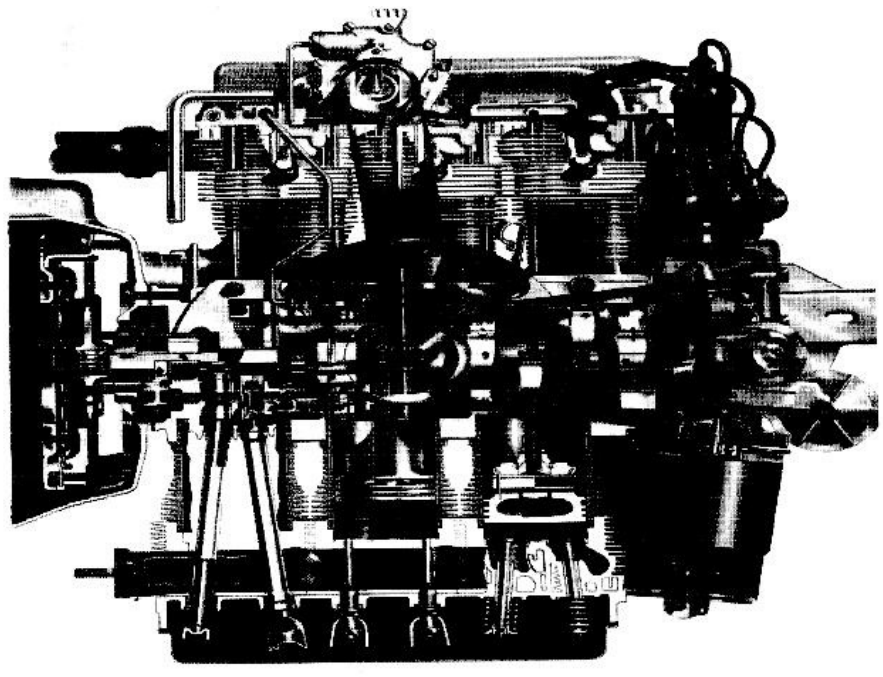

Prairie Capital Corvair Association

Prairie Capital
Corvair Association
P.O. Box 454
Pawnee, IL 62558

