



President's Corner - Don Wagner

This month the club's activities are coming to an end. Here are what you can look forward to Sept. 6th at Zona Rosa, 5:30 to 9:00pm for car display, also Oklahoma City Corvair Roundup Sept. 12-14th, or go to the Shriners' Show out to the Woodlands on the 14th. We have the Overland Park parade on Sept. 27th in the afternoon. If you can help out on the parade (convertibles) please call Jack Hill at (816-452-0619). If you have not made it to any of the events that we have had this year try to make one or a meetings. This last meeting if you didn't make it (we were in Alaska) we missed Kevin Koch's daughter, Gwen gave a very interesting program on her climb of Kilimanjaro Mountain in East Africa. (Thanks Kevin & Gwen) We had 9 cars show at the Westport Flea Market Bar and Grill and a new member, Tim Macho, showed his 65 pink convertible. Mike Sloan, thank you for your social and I hear good comments on it. If you are going to Oklahoma City and would like to caravan down to the roundup, contact Gary Moore (816-296-7819). Dominique Allen will be running the Show at Zona Rosa on Sept. 6th(a car display), and he would like to have you contact him, so he would know how big of an area he will need for the cars (816-668-3847). I could use help at the Oklahoma City roundup to judge and score Concours. In the next month or two the club will be looking for new officers to run the club for 2009, so if someone talks to you about being an officer, please help them out.

Inside this issue:

President's Corner	1
Preventative Maintenance	2
Take Aim	3
KCI Cruise Night	4
Zona Rosa Car Display with Hill Crest Ministries	5
Calendar of events New/returning members	6
Adds	7

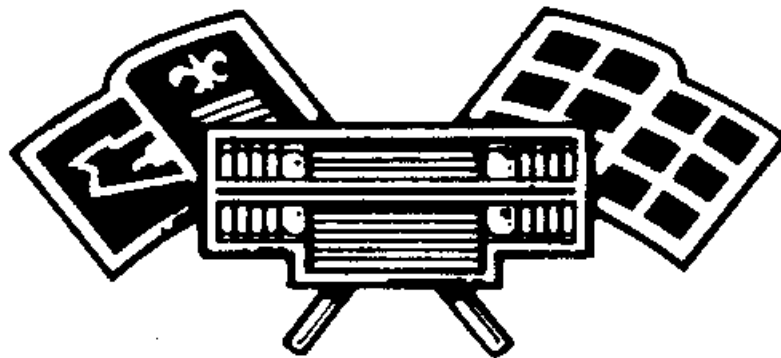

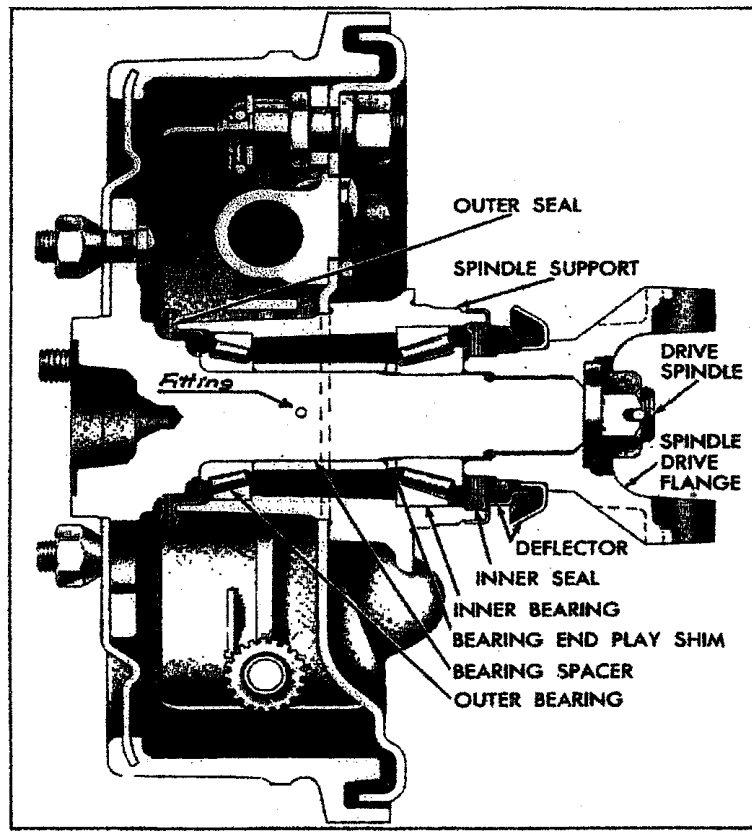

Fig. 66—Wheel Spindle and Support Cross Section

Packing Rear Wheel Bearings: 1965-1969

1. Remove brake shoes and outer U-joint so you can feel the bearings as you rotate the hub by hand.
2. Drill and tap a hole for a grease fitting, $\frac{1}{2}$ inch out from the backing plate. Drill a $\frac{1}{8}$ inch pilot hole, and then use a #3 bit. Tap for $\frac{1}{4}$ - 28, which is the standard grease fitting thread. Other sizes could be used. Coat the tap with grease to catch chips.
3. Use a high quality wheel bearing grease in a gun to pack the bearings as you check the turning of the bearings by hand after about 20 pumps (if this is the first packing). The fitting is installed between the two bearings and the new grease forces the old grease to the outside of the bearing against the seal. As you reach the proper amount of grease, the rotating of the hub will suddenly be quieter and show resistance to turning. At this point, remove the fitting and let any trapped air out. Reinstall the fitting and use two or three more pumps to complete packing.
4. Do not over pack, as you can pop the outer seal out of the hub (replace it with two prybars). Also, too much grease can find its way on to your brake shoes. If you suspect this, drive at highway speed for a few minutes, remove the fitting to check for excess pressure, and clean brakes if necessary with brake cleaner.
5. You can repack the bearings again after 20,000 miles by following #1 above but only using a few pumps of grease.

Take Aim

When you are in traffic and your horn is not effective to share your sentiments, nor are a variety of hand gestures, I have come up with a new communication method, Automotive Instant Messaging or AIM. A politically correct group of phrases to inform other drivers of their somewhat less than perfect driving would be installed in your car and play either verbally through the other car's radio or visually on their screen or dial. Here are some examples that may become standard AIM messages. "Does your accelerator not work properly or was it optional"? "Do your turn signals not work or were they optional"? "How many lanes does your vehicle require"? "Do you always travel in PARK on the freeway"? "Have you considered driving at the posted speed limit"? "Is it dark enough for you to consider using your headlights"? "Please say good bye to your caller and call them back when you stop". "My GPS Turtle Sensor tells me that you will never win the race with the hare". "Have you ever thought about joining the Demolition Derby and do you consider this practice"? "What color was that last light"? "Do you understand the term Right of Way"? "Go green by trading in your rust bucket of bolts and save everyone". "In order to have a clean car you may actually have to wash it". "Warp speed is from *Star Trek* and should only be used by the State Highway Patrol". "What part of pull over for those emergency vehicles did you not understand"? "Yield is something you should be doing, and not all of us to you". "Did your bumper sticker "I brake for nothing" come as standard equipment"? "Say, what kind of vehicle is that under all that ice and snow"?

These are just a few of the thoughts that run through my mind as I drive. Please share yours with me so we may grow this list at bowtieguy@cox.net.

Car Stolen

Did you know that a car is stolen every 26 seconds in this country? Did you also know that half of all stolen vehicles had their keys in them? This is where the dumbing down of society hits home for the simple reason that who would leave their keys in their car in 2008? Please take your keys with you, lock your car, and do not store a spare car key on your vehicle. If you need a spare, store one in your wallet or purse for safe keeping. You also might consider etching your VIN (vehicle identification number) on each car window. Do it yourself kits are available for as low as \$14.95 at <http://www.etch-o-matic.biz/vin-etching/>. Will it ever make sense to lock a convertible? It will always be better to be safe than sorry.

Buying American: Not as Easy as It Used to Be

I bought Goodyear tires the last time I needed them for my regular car. Goodyear has a local plant here and I feel that I should support them. They have many plants all around the country and the world for that matter. Cooper Tire has plants in Korea. Ours is a global economy. The new Chevrolet Camaro will be built in Canada. The new Ford Fiesta will be built in Mexico. GM is closing plants in the USA and this is what happens. Foreign companies are investing in the US and building factories here as we have invested for years in their countries. The hottest selling car in China is a Buick. In the recent downward sales trends, GM, Ford and Chrysler have been buoyed by sales outside the US. The new Saturns have transmissions built in Germany and are assembled in Belgium. Multi national cooperation has lead to hybrid technology sharing and the direct injection engine that gives gas mileage like a diesel engine. When you want to buy American, it may be necessary to follow the money trail. Buying at home, with companies that offer service after the sale, may make these decisions easier. Taking care of customers and employees is what we all need from our companies, US based or not.

KCI Cruise Night
October 4
4-8 p.m.

The Kansas City Aviation Department is holding another KCI Cruise Night Saturday, October 4. The fall KCI Cruise will be October 4 from 4 to 8 p.m. at the Ambassador Building at KCI at 12200 NW Ambassador Drive east of KCI and I-29.

Cruise Nights are sort of a misnomer, as classic, muscle and special interest cars are parked and people walk around and look at and talk about cars. Entry/admission is free and proceeds from drawings and food go toward local charities. The setting is casual, so bring a lawn chair and don't worry about vehicle judging!

Vendors are welcome for a \$25 fee, plus a portion of their proceeds. Banners are another way to promote your business. Please respond to me if you are interested.

An estimated 500 show cars and 300 spectator cars were present June 28 as were hundreds of attendees. And they came hungry as 850 hot dogs and dozens of cases of bottled water were consumed. The event generated \$2,285 for charity and someone went home with \$700 in their pocket from the 50/50 drawing!. We want to do better October 4, so tell all of your friends and come on out! Check out the web site for a map and video and photos from last time! Flyer attached. <http://www.flykci.com/cruise>

KCI Cruise Night

October 4, 4 - 8 p.m.

See hundreds of classic cars, muscle cars, hot rods, rat rods, exotics and imports near KCI Airport.

FREE ENTRY

Enter to win great prizes including a hotel stays, Richard Petty NASCAR ride-along, FREE car rentals, KCI Parking and more!! Enter a drawing to win a 1953 Ford Pick Up Hot Rod!
50/50 Drawing

Cheap Hot Dogs & Refreshments
Benefits Local Charities

Sign up for the KCI Rewards Frequent Parker Program where you can earn great gifts and free parking!

New location:

Ambassador Building at KCI
12200 NW Ambassador Drive, East of KCI and I-29

Directions

I-29 South to NW Cookingham Drive Exit. Turn left onto NW Cookingham Drive.

Turn left onto NW Ambassador Drive. Building is on the left.

I-29 North to Exit 13 (KCI Airport/St. Louis). Keep right onto I-435 E.

Exit onto NW Cookingham Drive. Left onto NW Ambassador Drive.

Building is on the left.

For more information contact:

joe_mcbride@kcmo.org

(816) 243-3164

flykci.com/cruise

65 Red Corvair Spider Turbo charge. Starts and runs. No Title- Parts Car. \$600.00 OBO call 816-506-7746.
Marion Herman

Wanted-A rebuilt 62-67 Corvair long block engine (102 or 110hp preferred) Please reply to Robert Strohm at 816-305-0334 or email me at glfgmjnkee@yahoo.com.

Thanks, Robert

Bill Ramm Overland Park, KS (Cell 913-579-7500) has a 1961 Parts for sale:

- 1-cylinder Head Gasket No. 3885124
- Pair of valve cover gaskets
- 1965 Corvair Shop Manual
- 1961 Corvair owners Guide
- Steering wheel (Blue) complete
- Tails lights Brake cyl and others things

Rebuilt Corvair Starters With New Solenoids \$85.00:

One year warranty, excluding broken noses due to bad ring gears. Mike Dawson 816-322-4057. Installation available.

For Sale:

- ♦ Headlight warning buzzers, \$10 - no charge for installation.
- ♦ Rebuilt Corvair starters including solenoid, one year warranty, \$85.00 exchange. (Installation available).
- ♦ Corvair alternators, rebuilt and converted to 63 amp internally regulated. One year warranty, \$70.00 exchange. (Installation available) Replace that generator!

Mike Dawson 816-322-4057

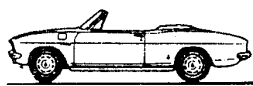
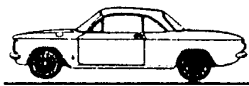

Cars & Parts

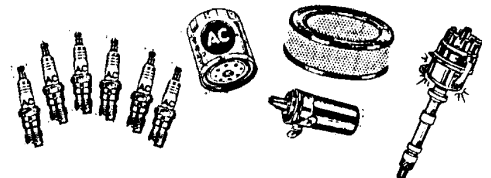

Tool Crib

Tool	Deposit	Rental Fee
Puller for Harmonic Balancer	\$3.00	\$1.00
Ramps, Auto	\$4.00	\$1.00
Torque Wrenches:		
1. 1/2" drive 20-150 lbs.	\$15.00	\$2.00
2. 3/8: drive 100-1000 lbs.	\$15.00	\$2.00
Floor Jack & Stands	\$25.00	\$3.50
Ring Grove Cleaner	\$3.00	\$1.00
Dwell-Tach Meter	\$5.00	\$1.00
Greaser: blower bearing & Idler Ply	\$5.00	\$1.00
Hubs, Rear Towing for LM powerglide	\$10.00	\$1.00

Contact: Ken Ragan

Ragan Enterprises

212 Warner Rd

Bonner Springs, KS 66012

913-422-5778

E-mail: kenrragan@sbcglobal.net

CORVAIR PARTS!

Since 1974 Corvair Underground has been selling parts and services to the Corvair community!

We offer new, used, rebuilt, NOS and reproduced parts as well as toy cars and collectibles.

Corvair Underground sells to every state in the Union plus all over Canada and the rest of the world. We accept all major credit cards and you can call, fax, mail or e mail your order.

Our giant 300 page mail order catalog, The Corvair Book, is just \$6.00 postpaid (USA). You can also get a subscription to our newsletter, The Corvair News, free. All we need is your name and address. Also, don't forget our online website www.corvairunderground.com. There you'll find our newsletter online, our GoVair performance and custom site and a whole lot more!

Find out why so many of your fellow Corvair owners save time, effort and especially money at

CORVAIR UNDERGROUND Inc. PO Box 339 Dundee, OR 97115

503-434-1648 800-825-8247 Fax 503-434-1626

Your Corvair Parts Supplier for the 21st Century!



2007 - 2012 Clark Catalog

This will be **THE Catalog** until 2013

Includes All our **NEW** parts, **KITS**, improvements and updates.

Over 6
solid months
in the making!

Includes
updates
on **80%** of
the pages!

Over
670 pages
1900 photos
1100 sketches

Over
500 exploded diagrams
14,000 parts listed
11,000 index entries

M - O - R - E
Clark Multi Kit choices,

How to Get One!

You need **THIS** catalog!

Rush order - **JUST** the catalog - Order over the internet or by any of our regular methods.
\$6.00 USA, \$8.00 Canada, FOREIGN contact us
WITH a Parts Order: order CAT-O \$4.00 3 Lbs.

CLARK'S CORVAIR PARTS,® INC.

400 Mohawk Trail Box C, Shelburne Falls, MA 01370 • 413-625-9776
www.corvair.com • e-mail: clarks@corvair.com



3 volume set

Will be used until **MAR. 2013**

CORVAIR
THE ONLY WAY TO GO!!

Heart Of America Corvair Owners Association

HACOA

16001 Oakland Ave.
Belton, MO 64012

Editor, Dominique Allen
Phone: 816-668-3847
E-mail: corvair@home-town.biz

**Oldest Incorporated Continually Active
Marquee Corvair Club**

2008 Officers & Directors

Don Wagner-Pres. 816-324-4870

Scott Allison-VP 816-847-8677

Elaine Richardson-Secretary 816-444-6954

Dominique Allen-Treasure 816-668-3847

Directors

Gary Moore 816-296-7819

Karl Cozad 816-741-2696

Jack Richardson 816-444-6954

Travis Bolton-Ex-Officio 816-792-2682



VairCor is the official publication of the Heart of America Corvair Owners Association, the oldest incorporated continuously active marquee Corvair club and Chapter 640 of the Corvair Society of America. The membership fee in HACOA is \$15.00 annually, payable January 1. CORSA membership is required. HACOA monthly meetings are held the second Tuesday of each month at 7:30 pm., 7:00 pm Social at Chappell's. 323 Armour Rd North Kansas City, MO 64116

September Calendar

- September 6th** **Zona Rosa Car Display with Hill Crest Ministries 5:30pm to 9pm.**
 - September 9th** **Meeting at Chappell's**
6:45 Board 7:00 Social 7:30 Very Little Business Just Fun - Come join in
 - September 12-14** **4th Annual Corvair Roundup in Oklahoma City, OK**
 - September 27** **Overland Park Parade**
 - October 4** **KCI Cruise Night**
 - October 14** **Meeting at Chappell's**
6:45 Board 7:00 Social 7:30 Very Little Business Just Fun - Come join in
-