

900 Series (Series Features . . . pages 2-3)

- Corvair 900 Monza 4-Door Sedan (6-Passenger)
- Corvair 900 Monza Club Coupe (2-Door 4-Passenger)
- Corvair 900 Monza 4-Door Station Wagon (6-Passenger)

700 Series (Series Features . . . pages 8-9)

- Corvair 700 4-Door Sedan (6-Passenger)
- Corvair 700 Club Coupe (2-Door 5-Passenger)
- Corvair 700 4-Door Station Wagon (6-Passenger)

500 Series (Series Features . . . pages 16-17)

- Corvair 500 Club Coupe (2-Door 5-Passenger)

Corvair Greenbrier (Series Features . . . pages 20-21)

- Greenbrier Sports Wagon (6-Door 6-Passenger)
- Greenbrier De Luxe Sports Wagon
- Greenbrier Taxicab Equipment
- Greenbrier Special Custom Features

MODEL NO.	PAGE
969	4-5
927	6-7
935	7A-7B
769	10-11
727	12-13
735	14-15
527	18-19
R1206	22-23
R1206 W/RPO 431	24
R1206	25
	26-27

POWER TEAMS . . . pages 28-31, BODY FEATURES . . . pages 32 and 34, CHASSIS SPECIFICATIONS . . . pages 33 and 35, OPTIONS AND ACCESSORIES . . . pages 36-37

Corvair 900 Monza Models

- 4-DOOR SEDAN
- CLUB COUPE
- 4-DOOR 6-PASSENGER STATION WAGON

Series Features . . .

(in addition to or replacing Corvair 700 or 500 equipment)

- Distinctive exterior trim
- Ultra-luxurious color-keyed interiors
- Extra-quality interior features and appointments
- Color-keyed deep-twist carpeting
- Foam-backed fabric front luggage compartment mat
- Plus all the quality features illustrated

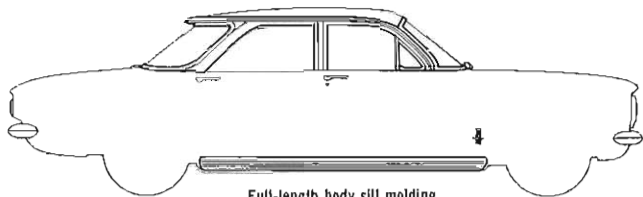

Full-length body sill molding.

Stainless steel roof drip cap molding, center pillar molding, and window frames on Sedan and Club Coupe. For Station Wagon trim see page 7A.



Full wheel covers.



Special Monza front fender nameplate and emblem.

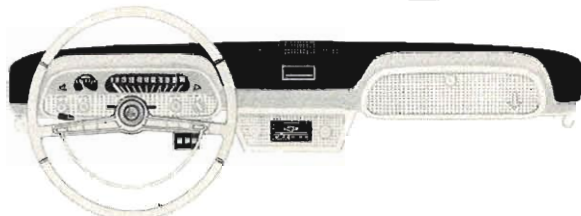

De Luxe dual-spoke steering wheel with chromed half-circle ring horn control. Instrument panel features cigarette lighter, ashtray, chrome-capped control knobs, anodized aluminum instrument cluster trim plate and molding, anodized aluminum glove compartment door trim plate and molding, glove compartment lock and light, and Monza nameplate and emblem.

Monza Series Features

Distinctive Monza door trim, dual-styled door opening and window regulator handles, and color-keyed armrests with bright-metal finish bases. (Rear armrests standard on Sedan and Station Wagon)

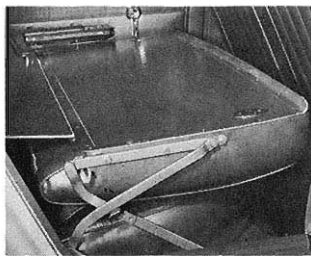

Convenient fold-down rear seat.

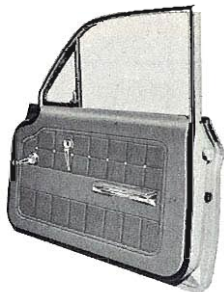

Individual self-vinyl foam-cushioned bucket front seats with anodized aluminum seat end panels. Standard on Club Coupe. Optional on Sedan and Station Wagon—Includes all-vinyl rear seat.

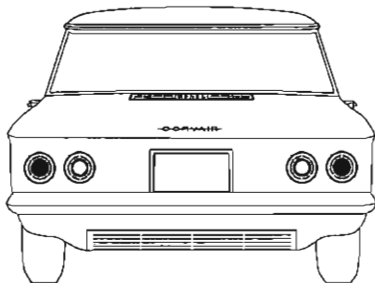
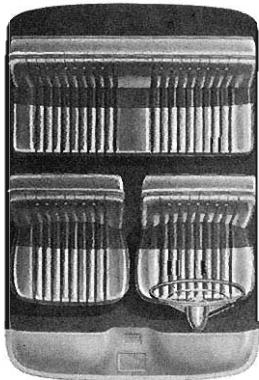

Simulated vents below rear window and bright-metal license plate recess opening framing on Sedan and Club Coupe. Twin-unit taillights and back-up lights standard on all models.

Monza Series Features

PLUS... ALL THESE CORVAIR QUALITY FEATURES

- Monostrut Body by Fisher
- Magic-Mirror acrylic lacquer finish
- Safety Plate Glass in every window
- High-Level ventilation system
- Built-in forced-air heater and defroster system
- Single-key lock system
- Adjustable sun visors
- Friction-type ventipanes
- Enclosed steering column
- Directional signals with twin indicator lights in instrument cluster
- Locking front luggage compartment
- Parallel-action electric windshield wipers
- Unipack power team—rear mounted engine and transaxle
- Quadriflex 4-wheel independent suspension
- Air-cooled Safety-Master brakes
- Low-friction Ball-Race steering
- Statically balanced wheels and tires
- Simulated front grille
- Four-unit headlights with anodized aluminum frames
- Anodized aluminum engine air grille
- Deep-section wrap-around bumpers
- Pushbutton type, outside door handles
- Front door and luggage compartment weather-shielded key locks

Corvaair Monza 4-Door Sedan . . . 4-Door 6 Passenger

MODEL 969



MONZA 4-DOOR SEDAN FEATURES . . .

- Smart sedan styling with distinctive roof and rear window design
- Wide-opening 4-door convenience and easy entrance
- Ultra-luxurious interior (all vinyl trim with bucket front seat option)
- Full-length body sill moldings
- Twin-unit taillights and back-up lights
- Simulated vent below rear window
- Monza series nameplate and emblem
- Stainless steel full wheel covers
- Additional bright metal moldings and accents: windshield, rear window, roof drip cap, ventipane frames, door frames, pillar moldings, simulated front grille, front nameplate and emblem, deck lid nameplate, license plate recess opening frame, engine air grille.

PLUS . . . ALL THE BUILT-IN QUALITY STANDARD IN EVERY '62 CORVAIR

Monza 4-Door Sedan

INTERIOR APPOINTMENTS AND FEATURES...

- Luxurious pattern cloth and leather-grain vinyl color-keyed upholstery (all-vinyl front and rear seat upholstery with bucket front seat option)
- Embossed vinyl headlining
- Vinyl-covered adjustable sun visors
- Combination textured and leather-grain vinyl sidewall trim insert panels
- Color-keyed deep-twist carpet floor covering
- Foam-cushioned front seat
- Fold-down rear seat
- Bright metal instrument panel facing and molding
- Identifying Monza nameplate on instrument panel
- Cigarette lighter
- Glove compartment lock
- Glove compartment light
- De luxe dual-spoke steering wheel with chromed half-circle horn ring (dual horns)
- Bright metal backed rearview mirror
- Color-keyed front and rear armrests with bright finished bases
- Lift-out ashtrays in instrument panel and rear armrests
- Two coat hooks
- Central dome light with chromed bezel and instrument panel main light switch control
- Automatic front door dome light switches
- Friction-type ventipanes
- Dual-styled door opening and window regulator handles
- Foam-backed fabric front luggage compartment mat
- Lined interior storage compartment behind rear seat

TRIM AND COLOR SELECTIONS...

INTERIOR	RPO NUMBERS AND EXTERIOR COLORS**	
	SOLID	
RPO 759 769* Fawn	900—Tuxedo Black 903—Surf Green 905—Laurel Green 920—Autumn Gold 923—Roman Red	925—Coronna Cream 936—Ermine White 938—Adobe Beige 948—Honduras Maroon
RPO 748 719* Aqua	900—Tuxedo Black 917—Twilight Turquoise	918—Twilight Blue 936—Ermine White
RPO 782 785* Red	900—Tuxedo Black 920—Autumn Gold 923—Roman Red	936—Ermine White 938—Adobe Beige 940—Satin Silver
RPO 735 736* Blue	900—Tuxedo Black 912—Silver Blue 914—Nassau Blue	936—Ermine White 940—Satin Silver
RPO 793 799* Gold	900—Tuxedo Black 925—Coronna Cream 936—Ermine White	
RPO 715* Black	900—Tuxedo Black 917—Twilight Turquoise 918—Twilight Blue 923—Roman Red	925—Coronna Cream 936—Ermine White 940—Satin Silver 948—Honduras Maroon

SPECIFICATIONS

Wheelbase	108.0
Length (overall)	180.0
Height (loaded)	51.5
Road clearance (min.)	6.0
Tread: Front	54.5
Rear	54.5
Width (overall)	67.0
Interior Room:	Front Rear
Torso room	37.5 36.5
Leg room	44.0 36.5
Hip room	58.5 58.0
Shoulder room	54.0 53.5
Entrance height	29.0 27.5
Luggage Compartment:	
Loading height	27.0
Total volume (cu. ft.)	12.6
Usable luggage space (cu. ft.)	6.6
Inside luggage space—rear seat folded (cu. ft.)	16.5
Total glass area (sq. in.)	3381.7
Windshield area (sq. in.)	1122.8
Rear window area (sq. in.)	1104.2
Tire Size:	6.50 x 13
Turning Diameter: (feet)	
Curb-to-curb	39.3
Wall-to-wall	41.4
Steering Ratio: (overall)	23.5:1
Fuel tank capacity (gallons)	14

POWER TEAMS . . . pages 28-31, BODY FEATURES . . . page 32, CHASSIS SPECIFICATIONS . . . page 33, OPTIONS AND ACCESSORIES . . . pages 36-37.

*All vinyl bucket front seat option. **Two-tone colors not available

Monza 4-Door Sedan

CORVAIR-5

Corvair Monza Club Coupe . . . 2-Door 4-Passenger

MODEL 927

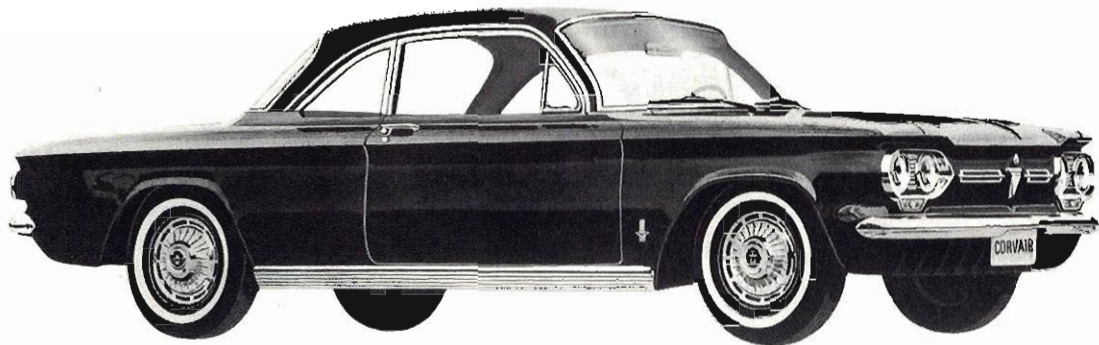

MONZA CLUB COUPE FEATURES . . .

- Distinctive roof and rear window design
- Wide-opening 2-door convenience and easy entrance
- Ultra-luxurious all vinyl interior with bucket front seats
- Full-length body sill moldings
- Twin-unit taillights and back-up lights
- Simulated vents below rear window
- Monza series nameplate and emblem
- Stainless steel full wheel covers
- Additional bright metal moldings and accents: windshield, rear window, roof drip cap, ventipane frames, door frame, center pillar, quarter window frame, simulated front grille, front nameplate and emblem, deck lid nameplate, license plate recess opening frame, engine air grille.

PLUS . . . ALL THE BUILT-IN QUALITY STANDARD IN EVERY '62 CORVAIR

Monza Club Coupe

INTERIOR APPOINTMENTS AND FEATURES ...

- Luxurious all-vinyl color-keyed seat upholstery
- Embossed vinyl headlining
- Vinyl-covered adjustable sun visors
- Combination textured and leather-grain vinyl sidewall trim insert panels
- Color-keyed deep-twist carpet floor covering
- Foam-cushioned bucket front seats
- Fold-down bucket-styled rear seat
- Bright metal instrument panel facing and molding
- Identifying Monza nameplate on instrument panel
- Cigarette lighter
- Glove compartment lock
- Glove compartment light
- De luxe dual-spoke steering wheel with chromed half-circle horn ring (dual horns)
- Bright metal backed rearview mirror
- Color-keyed front armrests with bright finished bases
- Lift-out ashtrays in instrument panel and rear quarter
- Two coat hooks
- Bright aluminum front seat end panels
- Central dome light with chromed bezel and instrument panel main light switch control
- Automatic front door dome light switches
- Friction-type ventipanes
- Dual-styled door opening and window regulator handles
- Foam-backed fabric front luggage compartment floor mat
- Lined interior stowage compartment behind rear seat

TRIM AND COLOR SELECTIONS ...

INTERIOR	RPO NUMBERS AND EXTERIOR COLORS*	
	SOLID	
RPO 758 Fawn	900—Tuxedo Black	925—Coronna Cream
	903—Surf Green	936—Ermine White
	905—Laurel Green	938—Adobe Beige
	920—Autumn Gold	948—Honduras Maroon
	923—Roman Red	
RPO 755 Aqua	900—Tuxedo Black	918—Twilight Blue
	917—Twilight Turquoise	936—Ermine White
RPO 781 Red	900—Tuxedo Black	936—Ermine White
	920—Autumn Gold	938—Adobe Beige
	923—Roman Red	940—Satin Silver
RPO 732 Blue	900—Tuxedo Black	936—Ermine White
	912—Silver Blue	940—Satin Silver
	914—Nassau Blue	
RPO 795 Gold	900—Tuxedo Black	
	925—Coronna Cream	
	936—Ermine White	
RPO 712 Black	900—Tuxedo Black	925—Coronna Cream
	917—Twilight Turquoise	936—Ermine White
	918—Twilight Blue	940—Satin Silver
	923—Roman Red	948—Honduras Maroon

SPECIFICATIONS

Wheelbase	108.0	
Length (overall)	180.0	
Height (loaded)	51.5	
Road clearance (min.)	6.0	
Tread: Front.....	54.5	
Rear.....	54.5	
Width (overall)	67.0	
Interior Room:	Front	Rear
Torso room	37.5	37.0
Leg room	43.0	31.0
Hip room	58.5	57.0
Shoulder room	54.0	52.0
Entrance height	28.5	—
Luggage Compartment:		
Loading height	27.0	
Total volume (cu. ft.)	12.6	
Usable luggage space (cu. ft.)	6.6	
Inside luggage space—rear seat folded (cu. ft.)	16.5	
Total glass area (sq. in.)	3219.2	
Windshield area (sq. in.)	1122.8	
Rear window area (sq. in.)	1069.2	
Tire Size	6.50 x 13	
Turning Diameter: (feet)		
Curb-to-curb	39.3	
Wall-to-wall	41.4	
Steering Ratio: (overall)	23.5:1	
Fuel tank capacity (gallons)	14	

POWER TEAMS ... pages 28-31, BODY FEATURES ... page 32, CHASSIS SPECIFICATIONS ... page 33, OPTIONS AND ACCESSORIES ... pages 36-37.

*Two-tone colors not available

Monza Club Coupe

CORVAIR—7

Corvaair Monza Station Wagon . . . 4-Door 6-Passenger

MODEL 935

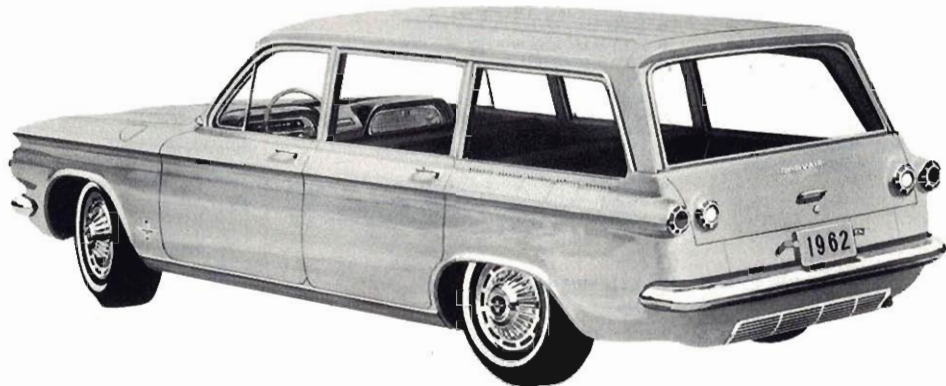

CORVAIR MONZA 4-DOOR STATION WAGON FEATURES . . .

- Smart Station Wagon styling with distinctive roof design
- Wide-opening 4-door convenience and easy entrance
- Ultra-luxurious color-keyed interior
- Positive locking, easy folding second seat
- Counterbalanced full opening liftgate
- Hood and body side moldings
- Full-length body sill moldings
- Twin-unit taillights and back-up lights
- Monza series nameplate and emblem
- Stainless steel full wheel covers
- Additional bright metal moldings and accents: windshield, tailgate window, roof drip cap, ventipane frames, simulated front grille, front nameplate and emblem, tailgate nameplate, and engine air grille.

PLUS . . . ALL THE BUILT-IN QUALITY STANDARD IN EVERY '62 CORVAIR

Corvaair Monza 4-Door Station Wagon

INTERIOR APPOINTMENTS AND FEATURES...

- Luxurious pattern cloth and leather-grain vinyl color-keyed upholstery (all-vinyl front and rear seat upholstery with bucket front seat option)
- Embossed vinyl headlining
- Vinyl-covered adjustable sun visors
- Combination textured and leather-grain vinyl sidewall trim insert panels
- Color-keyed deep-twist carpet floor covering
- Foam-cushioned seats
- Bright metal instrument panel facing and molding
- Identifying Monza nameplate on instrument panel
- Cigarette lighter
- Glove compartment lock
- Glove compartment light
- De luxe dual-spoke steering wheel with chromed half-circle horn ring (dual horns)
- Bright metal backed rearview mirror
- Color-keyed front and rear armrests with bright finished bases
- Lift-out ashtrays in instrument panel and rear armrests
- Two coat hooks
- Central dome light with chromed bezel and instrument panel main light switch control
- Automatic front door dome light switches
- Friction-type ventpanes
- Dual-styled door opening and window regulator handles
- Foam-backed fabric front luggage compartment mat
- Color-keyed padded deep-twist carpet cargo floor covering

TRIM AND COLOR SELECTIONS...

INTERIOR	RPO NUMBERS AND EXTERIOR COLORS	
	SOLID	
RPO 759 769* Fawn	900—Tuxedo Black 903—Surf Green 905—Laurel Green 920—Autumn Gold 923—Roman Red	925—Coronna Cream 936—Ermine White 938—Adobe Beige 948—Honduras Maroon
RPO 748 719* Aqua	900—Tuxedo Black 917—Twilight Turquoise	918—Twilight Blue 936—Ermine White
RPO 782 785* Red	900—Tuxedo Black 920—Autumn Gold 923—Roman Red	936—Ermine White 938—Adobe Beige 940—Satin Silver
RPO 735 736* Blue	900—Tuxedo Black 912—Silver Blue 914—Nassau Blue	936—Ermine White 940—Satin Silver
RPO 793 799* Gold	900—Tuxedo Black 925—Coronna Cream 936—Ermine White	
RPO 715* Black	900—Tuxedo Black 917—Twilight Turquoise 918—Twilight Blue 923—Roman Red	925—Coronna Cream 936—Ermine White 940—Satin Silver 948—Honduras Maroon

SPECIFICATIONS

Wheelbase.....	108.0	
Length (overall).....	180.0	
Height (loaded).....	53.5	
Road clearance (min.).....	6.0	
Tread: Front.....	54.5	Rear..... 54.5
Width (overall).....	67.0	
Interior Room:	Front	2nd Seat
Torso room.....	39.0	39.0
Leg room.....	44.0	36.5
Hip room.....	58.5	58.0
Shoulder room.....	54.0	53.5
Entrance height.....	29.0	29.5

Cargo Compartment:

Load floor length:	Liftgate closed	Liftgate open
Behind front seat.....	77.0	79.5
Behind second seat.....	47.0	49.5
Load floor width: Maximum overall.....	57.0	
Between wheel houses.....	39.0	
Maximum height—load floor to headlining.....	26.5	
Rear cargo deck loading height.....	26.5	
Rear entrance opening: Height.....	25.5	
Width—at floor.....	46.5	
Width—at belt.....	49.5	
Total cargo volume (cu. ft. incl. 10-cu.-ft. front trunk).....	68.0	

Total glass area (sq. in.).....	4240.4
Windshield area (sq. in.).....	1205.8
Rear window area (sq. in.).....	663.3
Tire Size.....	7.00 x 13
Turning Diameter: (feet)	
Curb-to-curb.....	39.3
Wall-to-wall.....	41.4
Steering Ratio: (overall).....	23.5:1
Fuel tank capacity (gallons).....	14

POWER TEAMS... pages 28-31, BODY FEATURES... page 32, CHASSIS SPECIFICATIONS... page 33, OPTIONS AND ACCESSORIES... pages 36-37.

*Bucket front seats and all-vinyl interior option.

Monza 4-Door Station Wagon

CORVAIR-7B

Corvaair 700 Models

- 4-DOOR SEDAN
- CLUB COUPE
- 4-DOOR 6-PASSENGER STATION WAGON

Series Features . . .

(in addition to or replacing Corvaair 500 equipment)

- Distinctive exterior trim
- Luxurious color-keyed interiors
- Extra-quality interior features and appointments
- Color-keyed vinyl-coated rubber floor covering
- Foam-backed fabric front luggage compartment mat
- Plus all the quality features illustrated

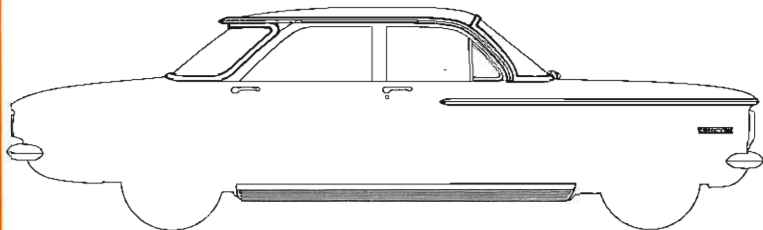

Stainless steel windshield and rear window moldings. Full-length body sill molding. Stainless steel roof drip cap molding. Stainless steel front and body side moldings.



Distinctive front fender nameplate and emblem.



Dual-spoke steering wheel with chromed center button horn control. Instrument panel features cigarette lighter, ashtray, chrome-capped control knobs, instrument cluster and glove compartment door anodized aluminum trim plates, glove compartment lock, and Corvaair 700 nameplate and emblem.

Corvaair 700 Series Features

Combination stop, tail, and directional lights with anodized aluminum bezels, and anodized aluminum bezels and cover plates for back-up lights.

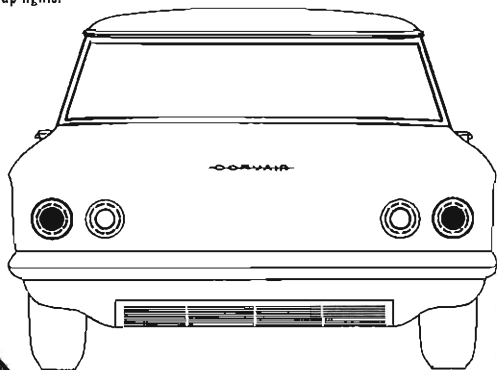

Distinctive Corvair 700 door trim, color-keyed front door armrests, and single-arm styled door opening and window regulator handles.



Corvair 700 Series Features

PLUS . . . ALL THESE CORVAIR QUALITY FEATURES

- Monostrut Body by Fisher
- Magic-Mirror acrylic lacquer finish
- Safety Plate Glass in every window
- High-Level ventilation system
- Built-in forced-air heater and defroster system
- Single-key lock system
- Adjustable sun visors
- Friction-type ventipanes
- Enclosed steering column
- Directional signals with twin indicator lights in instrument cluster
- Locking front luggage compartment
- Parallel-action electric windshield wipers
- Unipack power team—rear mounted engine and transaxle
- Quadriflex 4-wheel independent suspension
- Air-cooled Safety-Master brakes
- Low-friction Ball-Race steering
- Statically balanced wheels and tires
- Simulated front grille
- Four-unit headlights with anodized aluminum frames
- Anodized aluminum engine air grille
- Deep-section wrap-around bumpers
- Pushbutton type outside door handles
- Front door and luggage compartment weather-shielded key locks

Corvair 700 4-Door Sedan . . . 4-Door 6 Passenger

MODEL 769



CORVAIR 700 4-DOOR SEDAN FEATURES . . .

- Smart sedan styling with distinctive roof and rear window design
- Wide-opening 4-door convenience and easy entrance
- Luxurious color-keyed interior
- Hood and body side moldings
- Full-length body sill moldings
- Single taillight each side, plus provision for back-up lights
- Corvair 700 series nameplate and emblem
- Stainless steel hub caps (optional full wheel covers illustrated)
- Additional bright metal moldings and accents: windshield, rear window, roof drip cap, ventipane frames, simulated front grille, front nameplate and emblem, deck lid nameplate, back-up light cover plate and bezel, engine air grille.

PLUS . . . ALL THE BUILT-IN QUALITY STANDARD IN EVERY '62 CORVAIR

Corvair 700 4-Door Sedan

INTERIOR APPOINTMENTS AND FEATURES . . .

- Luxurious pattern cloth and leather-grain vinyl color-keyed seat upholstery
- Light-tone cloth headlining
- Adjustable sun visors
- Combination ribbed and leather-grain vinyl sidewall trim insert panels
- Color-keyed vinyl-coated rubber floor covering
- Foam-cushioned front seat
- Bright metal instrument panel facing
- Identifying Corvair 700 nameplate on instrument panel
- Cigarette lighter
- Dual-spoke steering wheel with chromed center button horn control (dual horns)
- Glove compartment lock
- Adjustable rearview mirror
- Color-keyed front armrests
- Two coat hooks
- Central dome light with instrument panel main light switch control
- Automatic front door dome light switches
- Friction-type ventipanes
- Single-arm styled door opening and window regulator handles
- Foam-backed fabric front luggage compartment floor mat
- Lined interior stowage compartment behind rear seat

TRIM AND COLOR SELECTIONS . . .

INTERIOR	RPO NUMBERS AND EXTERIOR COLORS		
	SOLID		TWO-TONE
RPO 757 Fawn	900—Tuxedo Black 903—Surf Green 905—Laurel Green 920—Autumn Gold 923—Roman Red	925—Coronna Cream 936—Ermine White 938—Adobe Beige 948—Honduras Maroon	950—Ermine White & Tuxedo Black 953—Ermine White & Surf Green 955—Surf Green & Laurel Green 970—Adobe Beige & Autumn Gold 973—Ermine White & Roman Red
RPO 751 Aqua	900—Tuxedo Black 918—Twilight Blue	917—Twilight Turquoise 936—Ermine White	950—Ermine White & Tuxedo Black 963—Ermine White & Twilight Blue 965—Twilight Turquoise & Twilight Blue
RPO 780 Red	900—Tuxedo Black 920—Autumn Gold 923—Roman Red	936—Ermine White 938—Adobe Beige 940—Satin Silver	950—Ermine White & Tuxedo Black 970—Adobe Beige & Autumn Gold 973—Ermine White & Roman Red
RPO 731 Blue	900—Tuxedo Black 912—Silver Blue 914—Nassau Blue	936—Ermine White 940—Satin Silver	950—Ermine White & Tuxedo Black 959—Ermine White & Silver Blue 962—Silver Blue & Nassau Blue 984—Ermine White & Satin Silver

SPECIFICATIONS

Wheelbase	108.0
Length (overall)	180.0
Height (loaded)	51.5
Road clearance (min.)	6.0
Tread: Front	54.5
Rear	54.5
Width (overall)	67.0
Interior Room:	Front Rear
Torso room	37.5 36.5
Leg room	44.0 36.5
Hip room	58.5 58.0
Shoulder room	54.0 53.5
Entrance height	29.0 27.5
Luggage Compartment:	
Loading height	27.0
Total volume (cu. ft.)	12.6
Usable luggage space (cu. ft.)	6.6
Total glass area (sq. in.)	3381.7
Windshield area (sq. in.)	1122.8
Rear window area (sq. in.)	1104.2
Tire Size:	6.50 x 13
Turning Diameter: (feet)	
Curb-to-curb	39.3
Wall-to-wall	41.4
Steering Ratio: (overall)	23.5:1
Fuel tank capacity (gallons)	14

POWER TEAMS . . . pages 28-31, BODY FEATURES . . . page 32, CHASSIS SPECIFICATIONS . . . page 33, OPTIONS AND ACCESSORIES . . . pages 36-37.

Corvair 700 4-Door Sedan

Corvair 700 Club Coupe . . . 2-Door, 5-Passenger

MODEL 727

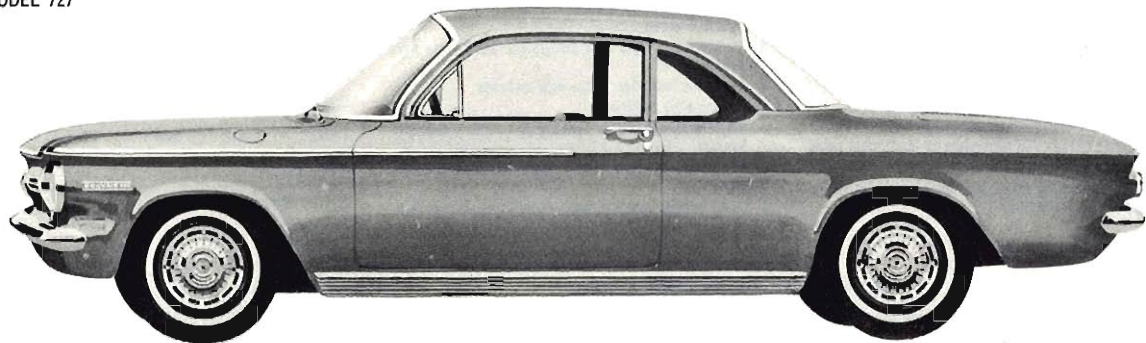

CORVAIR 700 CLUB COUPE FEATURES . . .

- Distinctive roof and rear window design
- Wide-opening 2-door convenience and easy entrance
- Luxurious color-keyed interior
- Hood and body side moldings
- Full-length body sill moldings
- Single taillight each side, plus provision for back-up lights
- Corvair 700 series nameplate and emblem
- Stainless steel hub caps (optional full wheel covers illustrated)
- Additional bright metal moldings and accents: windshield, rear window, roof drip cap, ventipane frames, simulated front grille, front nameplate and emblem, deck lid nameplate, back-up light cover plate and bezel, engine air grille.

PLUS . . . ALL THE BUILT-IN QUALITY STANDARD IN EVERY '62 CORVAIR

Corvair 700 Club Coupe

INTERIOR APPOINTMENTS AND FEATURES...

- Luxurious pattern cloth and leather-grain vinyl color-keyed seat upholstery
- Light-tone cloth headlining
- Adjustable sun visors
- Combination ribbed and leather-grain vinyl sidewall trim insert panels
- Color-keyed vinyl-coated rubber floor covering
- Foam-cushioned front seat
- Bright metal instrument panel facing
- Identifying Corvair 700 nameplate on instrument panel
- Cigarette lighter
- Dual-spoke steering wheel with chromed center button horn control (dual horns)
- Glove compartment lock
- Adjustable rearview mirror
- Color-keyed front armrests
- Two coat hooks
- Central dome light with instrument panel main light switch control
- Automatic front door dome light switches
- Friction-type ventipanes
- Single-arm styled door opening and window regulator handles
- Foam-backed fabric front luggage compartment floor mat
- Lined interior stowage compartment behind rear seat

TRIM AND COLOR SELECTIONS...

INTERIOR	RPO NUMBERS AND EXTERIOR COLORS		
	SOLID		TWO-TONE
RPO 757 Fawn	900—Tuxedo Black 903—Surf Green 905—Laurel Green 920—Autumn Gold 923—Roman Red	925—Coronna Cream 936—Ermine White 938—Adobe Beige 948—Honduras Maroon	950—Ermine White & Tuxedo Black 953—Ermine White & Surf Green 955—Surf Green & Laurel Green 970—Adobe Beige & Autumn Gold 973—Ermine White & Roman Red
RPO 751 Aqua	900—Tuxedo Black 918—Twilight Blue	917—Twilight Turquoise 936—Ermine White	950—Ermine White & Tuxedo Black 963—Ermine White & Twilight Blue 965—Twilight Turquoise & Twilight Blue
RPO 780 Red	900—Tuxedo Black 920—Autumn Gold 923—Roman Red	936—Ermine White 938—Adobe Beige 940—Satin Silver	950—Ermine White & Tuxedo Black 970—Adobe Beige & Autumn Gold 973—Ermine White & Roman Red
RPO 731 Blue	900—Tuxedo Black 912—Silver Blue 914—Nassau Blue	936—Ermine White 940—Satin Silver	950—Ermine White & Tuxedo Black 959—Ermine White & Silver Blue 962—Silver Blue & Nassau Blue 984—Ermine White & Satin Silver

SPECIFICATIONS

Wheelbase.....	108.0	
Length (overall).....	180.0	
Height (loaded).....	51.5	
Road clearance (min.).....	6.0	
Tread: Front.....	54.5	Rear..... 54.5
Width (overall).....	67.0	
Interior Room:	Front	Rear
Torso room.....	37.5	36.5
Leg room.....	44.0	32.0
Hip room.....	58.5	57.0
Shoulder room.....	54.0	52.0
Entrance height.....	29.0	—
Luggage Compartment:		
Loading height.....	27.0	
Total volume (cu. ft.).....	12.6	
Usable luggage space (cu. ft.).....	6.6	
Total glass area (sq. in.).....	3219.2	
Windshield area (sq. in.).....	1122.8	
Rear window area (sq. in.).....	1069.2	
Tire Size:.....	6.50 x 13	
Turning Diameter: (feet)		
Curb-to-curb.....	39.3	
Wall-to-wall.....	41.4	
Steering Ratio: (overall).....	23.5:1	
Fuel tank capacity (gallons).....	14	

POWER TEAMS . . . pages 28-31, BODY FEATURES . . . page 32, CHASSIS SPECIFICATIONS . . . page 33, OPTIONS AND ACCESSORIES . . . pages 36-37.

Corvair 700 Club Coupe

CORVAIR-13

Corvair 700 Station Wagon . . . 4-Door 6 Passenger

MODEL 735



CORVAIR 700 4-DOOR STATION WAGON FEATURES . . .

- Smart Station Wagon styling with distinctive roof design
- Wide-opening 4-door convenience and easy entrance
- Luxurious color-keyed interior
- Positive locking, easy folding second seat
- Counterbalanced full opening liftgate
- Hood and body side moldings
- Full-length body sill moldings
- Single unit taillight each side, plus provision for back-up lights
- Corvair 700 series nameplate and emblem
- Stainless steel hub caps (optional full wheel covers illustrated)
- Additional bright metal moldings and accents: windshield, tailgate window, roof drip cap, ventipane frames, simulated front grille, front nameplate and emblem, tailgate nameplate, back-up light cover plate and bezel, engine air grille.

PLUS . . . ALL THE BUILT-IN QUALITY STANDARD IN EVERY '62 CORVAIR

Corvair 700 4-Door Station Wagon

INTERIOR APPOINTMENTS AND FEATURES...

- Luxurious pattern cloth and leather-grain vinyl color-keyed seat upholstery
- Embossed vinyl headlining
- Adjustable sun visors
- Combination ribbed and leather-grain vinyl sidewall trim insert panels
- Color-keyed vinyl-coated rubber floor covering
- Foam-cushioned front seat
- Bright metal instrument panel facing
- Identifying Corvair 700 nameplate on instrument panel
- Cigarette lighter
- Dual-spoke steering wheel with chromed center button horn control (dual horns)
- Glove compartment lock
- Adjustable rearview mirror
- Color-keyed front armrests
- Two coat hooks
- Central dome light with instrument panel main light switch control
- Automatic front door dome light switches
- Friction-type ventpanes
- Single-arm styled door opening and window regulator handles
- Foam-backed fabric front luggage compartment floor mat
- Color-keyed vinyl-coated padded rubber cargo floor

TRIM AND COLOR SELECTIONS...

INTERIOR	RPO NUMBERS AND EXTERIOR COLORS		
	SOLID		TWO-TONE
RPO 757 Fawn	900—Tuxedo Black 903—Surf Green 905—Laurel Green 920—Autumn Gold 923—Roman Red	925—Coronna Cream 936—Ermine White 938—Adobe Beige 948—Honduras Maroon	950—Ermine White & Tuxedo Black 953—Ermine White & Surf Green 955—Surf Green & Laurel Green 970—Adobe Beige & Autumn Gold 973—Ermine White & Roman Red
RPO 751 Aqua	900—Tuxedo Black 918—Twilight Blue	917—Twilight Turquoise 936—Ermine White	950—Ermine White & Tuxedo Black 963—Ermine White & Twilight Blue 965—Twilight Turquoise & Twilight Blue
RPO 780 Red	900—Tuxedo Black 920—Autumn Gold 923—Roman Red	936—Ermine White 938—Adobe Beige 940—Satin Silver	950—Ermine White & Tuxedo Black 970—Adobe Beige & Autumn Gold 973—Ermine White & Roman Red
RPO 731 Blue	900—Tuxedo Black 912—Silver Blue 914—Nassau Blue	936—Ermine White 940—Satin Silver	950—Ermine White & Tuxedo Black 959—Ermine White & Silver Blue 962—Silver Blue & Nassau Blue 984—Ermine White & Satin Silver

SPECIFICATIONS

Wheelbase	108.0	
Length (overall)	180.0	
Height (loaded)	53.5	
Road clearance (min.)	6.0	
Tread:	Front	Rear
	54.5	54.5
Width (overall)	67.0	
Interior Room:	Front	2nd Seat
Torso room	39.0	39.0
Leg room	44.0	36.5
Hip room	58.5	58.0
Shoulder room	54.0	53.5
Entrance height	29.0	29.5

Cargo Compartment:

Load floor length:	Liftgate closed	Liftgate open
Behind front seat	77.0	79.5
Behind second seat	47.0	49.5
Load floor width: Maximum overall	57.0	
	Between wheel houses	39.0
Maximum height—load floor to headlining	26.5	
Rear cargo deck loading height	26.5	
Rear entrance opening: Height	25.5	
	Width—at floor	46.5
	Width—at belt	49.5
Total cargo volume (cu. ft. incl. 10-cu.-ft. front trunk)	68.0	

Total glass area (sq. in.)	4240.4
Windshield area (sq. in.)	1205.8
Rear window area (sq. in.)	663.3

Tire Size 7.00 x 13

Turning Diameter: (feet)

Curb-to-curb	39.3
Wall-to-wall	41.4

Steering Ratio: (overall) 23.5:1

Fuel tank capacity (gallons) 14

POWER TEAMS . . . pages 28-31, BODY FEATURES . . . page 32, CHASSIS SPECIFICATIONS . . . page 33, OPTIONS AND ACCESSORIES . . . pages 36-37.

Corvair 700 4-Door Station Wagon

CORVAIR—15

Corvaair 500 Model

● CLUB COUPE

Series Features . . .

- Distinctive exterior trim
- Smartly styled color-keyed interiors
- Quality interior features and appointments
- Durable black rubber floor covering
- Plus all the quality features illustrated

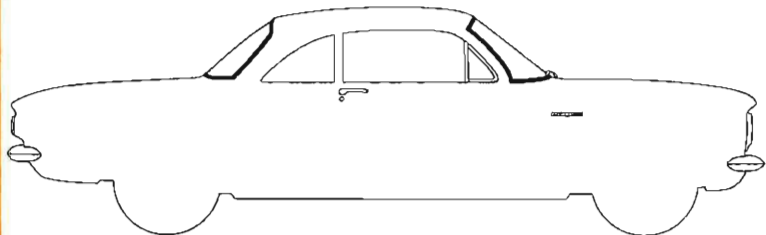

Positive weather-sealing windshield and rear window black rubber moldings.



Dual adjustable sun visors.

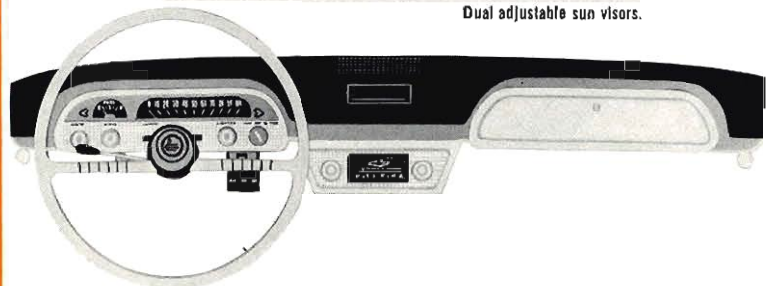

Dual-spoke steering wheel with chromed center button horn control. Instrument panel features cigarette lighter, ashtray, chrome-capped control knobs, instrument cluster anodized aluminum trim plate, glove compartment lock, and bright-painted glove compartment door.

Corvaair 500 Series Features

Combination stop, tail, and directional lights with anodized aluminum bezels, and anodized aluminum bezels and cover plates for back-up lights.

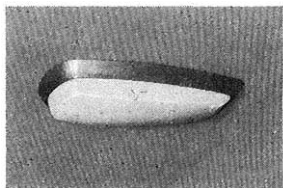

Central dome light with convenient instrument panel main light switch control.



Distinctive front fender nameplate and emblem.

CORVAIR 500

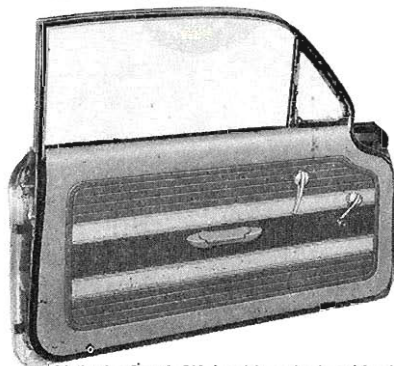

Distinctive Corvair 500 door trim, color-keyed front door armrests, and single-arm styled door opening and window regulator handles.

Foam-cushioned front seat.

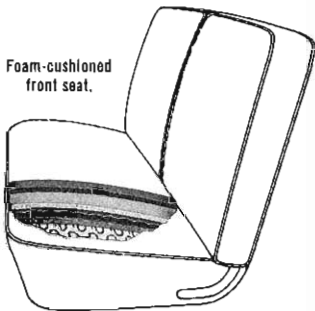

PLUS... ALL THESE CORVAIR QUALITY FEATURES

- Monostrut Body by Fisher
- Magic-Mirror acrylic lacquer finish
- Safety Plate Glass in every window
- High-Level ventilation system
- Built-in forced-air heater and defroster system
- Single-key lock system
- Adjustable sun visors
- Friction-type ventpanes
- Enclosed steering column
- Directional signals with twin indicator lights in instrument cluster
- Locking front luggage compartment
- Parallel-action electric windshield wipers
- Unipack power team—rear mounted engine and transaxle
- Quadriflex 4-wheel independent suspension
- Air-cooled Safety-Master brakes
- Low-friction Ball-Race steering
- Statically balanced wheels and tires
- Simulated front grille
- Four-unit headlights with anodized aluminum frames
- Anodized aluminum engine air grille
- Deep-section wrap-around bumpers
- Pushbutton type outside door handles
- Front door and luggage compartment weather-shielded key locks

Corvair 500 Series Features

Corvair 500 Club Coupe . . . 2-Door 5-Passenger

MODEL 527



CORVAIR 500 CLUB COUPE FEATURES . . .

- Distinctive roof and rear window design
- Wide-opening 2-door convenience and easy entrance
- Smartly styled color-keyed interior
- Single-unit taillight each side, plus provision for back-up lights
- Corvair 500 series nameplate and emblem
- Stainless steel hub caps
- Additional bright metal moldings and accents: ventipane frame, simulated front grille, front nameplate and emblem, deck lid nameplate, back-up light cover plate and bezel, engine air grille.

PLUS . . . ALL THE BUILT-IN QUALITY STANDARD IN EVERY '62 CORVAIR

Corvair 500 Club Coupe

INTERIOR APPOINTMENTS AND FEATURES...

- Color-keyed pattern cloth and leather-grain vinyl seat upholstery
- Light-tone cloth headlining
- Adjustable sun visors
- Combination ribbed and leather-grain vinyl sidewall trim insert panels
- Black rubber mat floor covering
- Foam-cushioned front seat
- Bright metal instrument cluster trim plate
- Cigarette lighter
- Glove compartment lock
- Dual-spoke steering wheel with chromed center button horn control (single horn)
- Adjustable rearview mirror
- Color-keyed front armrests
- Two coat hooks
- Central dome light with instrument panel main light switch control
- Friction-type ventpanes
- Single-arm styled door opening and window regulator handles
- Lined interior stowage compartment behind rear seat

TRIM AND COLOR SELECTIONS...

INTERIOR	RPO NUMBERS AND EXTERIOR COLORS		
	SOLID		TWO-TONE
RPO 756 Fawn	900—Tuxedo Black 903—Surf Green 905—Laurel Green 912—Silver Blue 914—Nassau Blue 920—Autumn Gold	923—Roman Red 925—Coronna Cream 936—Ermine White 938—Adobe Beige 948—Honduras Maroon	950—Ermine White & Tuxedo Black 953—Ermine White & Surf Green 955—Surf Green & Laurel Green 959—Ermine White & Silver Blue 962—Silver Blue & Nassau Blue 970—Adobe Beige & Autumn Gold 973—Ermine White & Roman Red
RPO 745 Aqua	900—Tuxedo Black 918—Twilight Blue	917—Twilight Turquoise 936—Ermine White	950—Ermine White & Tuxedo Black 963—Ermine White & Twilight Blue 965—Twilight Turquoise & Twilight Blue
RPO 779 Red	900—Tuxedo Black 920—Autumn Gold 923—Roman Red	936—Ermine White 938—Adobe Beige 940—Satin Silver	950—Ermine White & Tuxedo Black 970—Adobe Beige & Autumn Gold 973—Ermine White & Roman Red 984—Ermine White & Satin Silver

SPECIFICATIONS

Wheelbase.....	108.0
Length (overall).....	180.0
Height (loaded).....	51.5
Road clearance (min.).....	6.0
Tread: Front.....	54.5
Rear.....	54.5
Width (overall).....	67.0
Interior Room:	Front Rear
Torso room.....	37.5 36.5
Leg room.....	44.0 32.0
Hip room.....	58.5 57.0
Shoulder room.....	54.0 52.0
Entrance height.....	29.0 —
Luggage Compartment:	
Loading height.....	27.0
Total volume (cu. ft.).....	12.6
Usable luggage space (cu. ft.).....	6.6
Total glass area (sq. in.).....	3219.2
Windshield area (sq. in.).....	1122.8
Rear window area (sq. in.).....	1069.2
Tire Size.....	6.50 x 13
Turning Diameter: (feet)	
Curb-to-curb.....	39.3
Wall-to-wall.....	41.4
Steering Ratio: (overall).....	23.5:1
Fuel tank capacity (gallons).....	14

Corvair Greenbrier Models

- GREENBRIER SPORTS WAGON
- GREENBRIER DE LUXE SPORTS WAGON

Series Features . . .

- Large-capacity passenger and cargo carrying van-type design
- Six wide-opening doors for easy entrance and loading
- Smartly styled and appointed interiors
- Foam-cushioned seat cushions
- Extra-large, easily accessible cargo space
- Plus all the quality features illustrated



Dual-spoke steering wheel with center button horn control. Instrument panel features central ashtray, bright embossed aluminum instrument cluster insert panel, chrome-capped control knobs, glove compartment lock, white painted instrument panel front face, silver painted instrument cluster bezel and glove compartment door face. Standard Greenbrier instrument panel shown—see page 24, Corvair section for Greenbrier De Luxe additional instrument panel features.

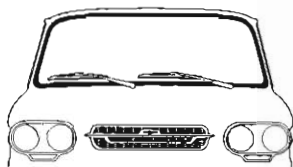

High, wide Safety Plate Glass windshield affords exceptional visibility.



Extra-large right-side double door openings and low step height for easy loading or entrance. Left-side double doors optional at extra cost.

Greenbrier Series Features



Big, wide-opening double rear doors offer easy access to rear cargo floor and can be fully opened for close-up loading. Hinged panel below rear doors permits quick access to engine for periodic maintenance and inspection.



Versatile full-width second seat is easily removed for greater cargo capacity, faces either to the front or rearward in the forward position (illustrated), or can be moved to rearward position facing front.

PLUS . . . ALL THESE QUALITY FEATURES

- Fully unitized body construction
- High-quality synthetic enamel finish
- High-Level ventilation system
- Single-key lock system
- Friction-type ventipanes
- Enclosed steering column
- Directional signals with twin indicator lights in instrument cluster
- Parallel-action electric windshield wipers
- Unipack power team—rear mounted engine and transaxle
- Quadriflex 4-wheel independent suspension
- Air-cooled Safety-Master brakes
- Low-friction Ball-Race steering
- Statically balanced wheels and tires
- Anodized aluminum front air intake grille
- Four-unit headlights with anodized aluminum frames
- Twin high-mounted combination parking lights and directional signal lights
- Pushbutton type outside door handles
- Front, side, and rear door weather-shielded key locks

Greenbrier Series Features

Corvair Greenbrier Sports Wagon . . . 6-Door 6-Passenger

MODEL R1206



GREENBRIER SPORTS WAGON FEATURES . . .

- Distinctively low van-type styling
- Wide-opening left and right front, double right side and double rear doors for convenient loading and easy entrance
- Smartly styled and appointed interior
- Full-width adjustable front seat
- Versatile 3-position, removable second seat
- Extra-large cargo compartment with low load floor
- Painted hub caps and bumpers
- Combined stop, tail, and directional signal lights
- Bright metal accents: anodized aluminum front air intake grille with Chevrolet nameplate and emblem, Greenbrier series nameplate on front doors, Corvair nameplate on rear door.

PLUS . . . ALL THE BUILT-IN BASIC QUALITY STANDARD IN EVERY '62 CORVAIR

Greenbrier Sports Wagon

INTERIOR APPOINTMENTS AND FEATURES . . .

- Medium fawn pattern cloth and textured vinyl seat upholstery
- Adjustable sliding left-hand sun visor
- Charcoal-color ribbed rubber floor covering
- Medium fawn color painted sidewalls
- Vinyl headlining between roof bows
- Foam-cushioned full-width seat cushions
- Removable, 3-position second seat
- Bright embossed instrument cluster insert panel
- Central ashtray on instrument panel
- Glove compartment lock
- Dual-spoke steering wheel with center horn button
- Central dome light with instrument panel main light switch control
- Friction-type ventipanes
- Roll-down front door and side windows
- Adjustable front seat with adjustable backrest
- Single-arm styled door opening and window regulator handles

TRIM AND COLOR SELECTIONS . . .

GREENBRIER

INTERIOR	EXTERIOR COLORS
Fawn	Standard Fawn interior with all solid and two-tone exterior colors shown below for Greenbrier De Luxe.

GREENBRIER DE LUXE

INTERIOR	RPO NUMBERS AND EXTERIOR COLORS	
	SOLID	TWO-TONE
Fawn Part of RPO 431	508—Balboa Blue 507—Brigade Blue 516—Omaha Orange 519—Yuma Yellow 528—Desert Beige 502—Seamist Jade 524—Tangier Gold	538—Balboa Blue & Cameo White 537—Brigade Blue & Cameo White 546—Omaha Orange & Cameo White 549—Yuma Yellow & Cameo White 558—Desert Beige & Cameo White 532—Seamist Jade & Cameo White 554—Tangier Gold & Cameo White
Turquoise Part of RPO 431	510—Crystal Turquoise 500—Jet Black	540—Crystal Turquoise & Cameo White 530—Jet Black & Cameo White
Red Part of RPO 431	514—Cardinal Red 521—Pure White 522—Georgian Gray 526—Cameo White	544—Cardinal Red & Cameo White 545—Pure White & Cardinal Red 552—Georgian Gray & Cameo White 541—Cameo White & Cardinal Red
Green Part of RPO 431	503—Glenwood Green 505—Woodland Green	533—Glenwood Green & Cameo White 535—Woodland Green & Cameo White

SPECIFICATIONS

Wheelbase	95.0
Length (overall)	179.7
Height (loaded)	68.5
Road clearance (min.)	6.6
Tread: Front	58.0
Rear	58.0
Width (overall)	70.0
Interior Room:	Front 2nd Seat
Torso room	39.7 39.7
Leg room	44.5 37.8
Hip room	61.4 61.6
Shoulder room	59.5 59.5
Entrance height	31.5 33.5

Cargo Compartment:

Center cargo area:

Double side door opening:

Width	53.0	Height	49.0
-------	------	--------	------

Step height-ground to floor level	16.2
-----------------------------------	------

Load floor: Length	53.0	Width	61.8
--------------------	------	-------	------

Maximum height—floor to roof	53.8
------------------------------	------

Rear cargo floor:

Double rear door opening:

Width	46.0	Height	35.4
-------	------	--------	------

Loading height	28.5
----------------	------

Load floor: Length	44.9	Width	44.5
--------------------	------	-------	------

Maximum height—floor to roof	39.7
------------------------------	------

Maximum interior load length behind front seat	117.5
--	-------

Total cargo volume (cu. ft.)	175.5
------------------------------	-------

Total glass area (sq. in.)	4790.0
----------------------------	--------

Windshield area (sq. in.)	1171.0
---------------------------	--------

Rear window area (sq. in.)	409.0
----------------------------	-------

Tire Size	7.00 x 14
-----------	-----------

Turning Diameter: (feet) Curb-to-curb	39.2
---------------------------------------	------

Wall-to-wall	42.6
--------------	------

Steering Ratio: (overall)	23:1
---------------------------	------

Fuel tank capacity (gallons)	18.5
------------------------------	------

POWER TEAMS . . . pages 28-31, BODY FEATURES . . . page 34, CHASSIS SPECIFICATIONS . . . page 35, OPTIONS AND ACCESSORIES . . . pages 36-37.

Greenbrier Sports Wagon

CORVAIR—23

Corvaair Greenbrier De Luxe Sports Wagon . . . 6-Door 6-Passenger

MODEL R1206
WITH RPO 431
DE LUXE EQUIPMENT



GREENBRIER DE LUXE SPORTS WAGON FEATURES . . . (in addition to or replacing standard Greenbrier equipment)

- Bright bumpers and hub caps (optional full wheel covers illustrated)
- Stainless steel windshield reveal molding
- Special red plastic taillight inserts
- Four color-keyed interiors with pattern cloth and textured vinyl seat upholstery
- Color-keyed vinyl sidewall panels with insert and bright molding
- Right and left adjustable sun visors
- White vinyl headlining between roof bows
- Instrument cluster and glove compartment door bright trim panels.
- De luxe color-keyed, two-toned steering wheel
- Color-keyed front door armrests
- Foam-cushioned seat cushions and backrests
- Cigarette lighter
- Color-keyed vinyl-coated rubber mat floor covering
- Charcoal colored textured vinyl spare tire cover
- Two bright metal second seat ashtrays
- Front and rear dome lights

FOR GREENBRIER DE LUXE SPORTS WAGON COLOR SELECTIONS AND SPECIFICATIONS . . . see page 23

Greenbrier De Luxe Sports Wagon

Greenbrier Taxicab Equipment . . .



GREENBRIER FACTORY-BUILT TAXICABS . . .

Special factory-installed body and chassis equipment package . . . engineered for rugged, stop-and-go taxicab service.

BODY EQUIPMENT . . .

- Fawn interior with all vinyl seat upholstery for extra durability and easy cleaning. Separate option third seat—all vinyl, fawn colored, RPO 269C.
- Heavy-duty front compartment rubber mat floor covering with special asphalt-impregnated waterproof underpad.
- Heavy-duty passenger compartment vinyl-coated rubber mat floor covering.
- Spare tire cover . . . prevents luggage from soiling or damage.
- Open-door warning light on instrument panel . . . switch on forward passenger compartment right-hand side door on standard model, and also on left-hand side front door with RPO 645, left-hand side double doors.

PLUS . . . ALL THE BUILT-IN QUALITY STANDARD IN EVERY '62 CORVAIR

For Trim & Color Selections and Specifications . . . see page 23, Corvair section.

POWER TEAMS . . . pages 28-31, BODY FEATURES . . . page 34, CHASSIS SPECIFICATIONS . . . page 35, OPTIONS AND ACCESSORIES . . . pages 36-37.

*Optional at extra cost.

CHASSIS EQUIPMENT . . .

- Heavy-duty front shock absorbers—special valving for improved full-passenger load ride control.
- Special universal joint lubrication fittings—allows quick lubrication of axle shaft universal joints . . . eliminates periodic repacking.
- Heavy-duty battery—40-ampere rating.

FACTORY-INSTALLED OPTIONS*

Wide range of additional factory-installed optional equipment available . . . for complete listing see page 36, Corvair section.

SPECIAL ORDER EQUIPMENT*

Other specialized equipment to meet the demands of unusual operating requirements may be obtainable on special order as factory-installed equipment through authorized Chevrolet dealer.

POWER TEAMS

Greenbrier factory-built taxicabs are available with 3-Speed Synchro-Mesh or optional 4-Speed Synchro-Mesh and Powerglide transmissions teamed to special heavy-duty 80-hp Turbo-Air 145 engine . . . for specific details see Power Team chart, transmission and engine specifications . . . pages 28 to 31, Corvair section.

CUSTOM FEATURE ACCESSORIES*

In addition to factory-installed equipment a wide variety of dealer-installed Custom Feature accessories suited for taxicab use are available. For complete listing see page 37, Corvair section.

Greenbrier Taxicab Equipment

CORVAIR—25

Greenbrier Special Custom Features . . .

OUTDOOR LIVING ACCESSORY EQUIPMENT . . .

Specially designed Custom Feature Accessories—in addition to regular dealer-installed accessories listed on page 37—for extending Greenbrier versatility to include a wide variety of outdoor business and pleasure uses. Available through authorized Chevrolet dealers.

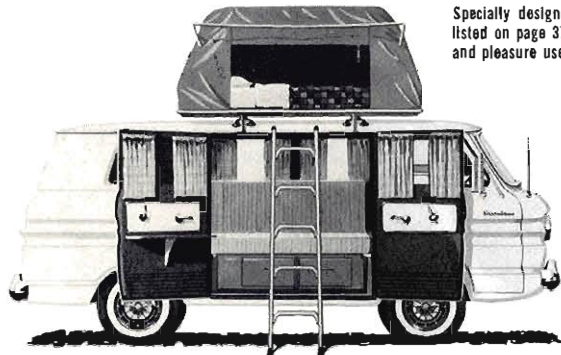

CUSTOM CAMPER UNIT (Part No. 985103)—Converts Greenbrier interior into a combination bedroom, living room, and kitchen. Includes foam-cushioned couch that converts to twin beds or single double bed, Formica-topped kitchen counter, clothes storage cabinet with door and mirror, 7-gallon capacity Coleman cooler, 1-gallon Coleman Jug, single-burner Coleman gas stove, door-mounted drop leaf table, vinyl floor covering, eight sets of drapes, plus convenient built-in storage drawers and compartments.

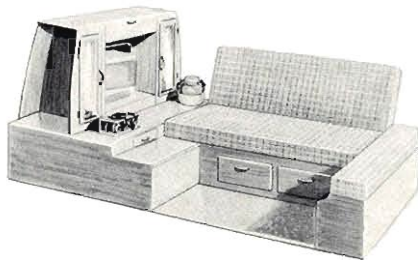

CARGO NET (Part No. 985104)—Extra-strong vinyl cargo net attaches to roof and floor, permitting full-height luggage stacking. Complete with five heavy-duty adjustable straps.

Greenbrier Special Custom Features

Greenbrier Special Custom Features . . .



SHELTER UNIT (Part No. 985106)—13' long, 10' wide at front, 7½' wide at rear. Complete with four aluminum poles, ropes, stakes, and rope tighteners. Made from 10 oz. Army Duck in red and white colors to match tent unit.



POP-UP TENT UNIT (Part No. 985101)—6'4" high with 8' x 10' sewn-in floor. Made from sail boat drill cloth (7.68 oz.) in red and white. Features 22" rear window with nylon mosquito netting and front zipper closure. Complete with eight stakes and fiber glass supporting ribs.

LUGGAGE CARRIER (Part No. 988398)—Securely attaches to roof—adds extra luggage capacity.



SLEEPER UNIT (Part No. 985102)—Car top sleeper unit 6½' long, 4' wide, and 33" high. Accommodates ¾ size double bed mattress or two 27" x 72" air mattresses. Complete with supports, safety straps, fillings, hardware, and 2-piece ladder.



SCREENS, SIDE WINDOWS (Part No. 985100)—Set of four for side window ventilation.



CUSTOM TABLE (Part No. 985107)—Large 2' x 4' removable table for either inside or outside use.



CHILD BED (Part No. 985359)—Fold-down child's bed converts front seat to added sleeping room.



DRAWER UNIT (Part No. 985105)—15" deep, 35" wide, 7" high. Installs under second seat.

Greenbrier Special Custom Features

1962 Corvair Power Teams . . .

ENGINE	3-SPEED SYNCHRO-MESH (STANDARD)	4-SPEED SYNCHRO-MESH (RPO 651 & 652**)	POWERGLIDE (RPO 360 & 667**)
<p>STANDARD ENGINE</p> <p>80-HP TURBO-AIR 145* (145-CU.-IN. 6)</p> <p>TWO SINGLE-BARREL CARBURETORS HYDRAULIC VALVE LIFTERS 8.0:1 COMPRESSION RATIO* (PREMIUM QUALITY BEARINGS ON GREENBRIER)</p>	<p>SEDANS & COUPES: STD.—3.27:1 AXLE OPT.—3.55:1 AND 3.89:1 AXLES</p> <p>STATION WAGON: STD.—3.55:1 AXLE OPT.—3.89:1 AXLE</p> <p>GREENBRIER: 3.89:1 AXLE ONLY</p>	<p>SEDANS & COUPES: STD.—3.27:1 AXLE OPT.—3.55:1 AND 3.89:1 AXLES</p> <p>STATION WAGON: STD.—3.55:1 AXLE OPT.—3.89:1 AXLE</p> <p>GREENBRIER: 3.89:1 AXLE ONLY</p>	<p>SEDANS & COUPES: STD.—3.27:1 AXLE OPT.—3.55:1 AND 3.89:1 AXLES</p> <p>STATION WAGON: STD.—3.55:1 AXLE OPT.—3.89:1 AXLE</p> <p>GREENBRIER: 3.89:1 AXLE ONLY</p>
<p>RPO 649 HIGH PERFORMANCE ENGINE</p> <p>102-HP TURBO-AIR 145 (145-CU.-IN. 6)</p> <p>TWO SINGLE-BARREL CARBURETORS HYDRAULIC VALVE LIFTERS SPECIAL PERFORMANCE CAMSHAFT 9.0:1 COMPRESSION RATIO PREMIUM QUALITY BEARINGS</p>	<p>SEDANS & COUPES: STD.—3.27:1 AXLE OPT.—3.55:1 AND 3.89:1 AXLES</p> <p>STATION WAGON: STD.—3.55:1 AXLE OPT.—3.89:1 AXLE</p>	<p>SEDANS & COUPES: STD.—3.27:1 AXLE OPT.—3.55:1 AND 3.89:1 AXLES</p> <p>STATION WAGON: STD.—3.55:1 AXLE OPT.—3.89:1 AXLE</p>	<p>SEDANS & COUPES: STD.—3.55:1 AXLE OPT.—3.89:1 AXLE</p> <p>STATION WAGON: STD.—3.55:1 AXLE OPT.—3.89:1 AXLE</p>

*In Monza models equipped with Powerglide: compression ratio—9.0:1, hp—84 @ 4400.

**Greenbrier RPO

Note: Optional Positraction rear axle available with standard and optional axle ratios.

1962 Corvair Transmissions . . .

3-SPEED SYNCHRO-MESH

Standard with all engines. Manually operated 3-speed transmission with synchronized second and third gear operation. Floor mounted gearshift lever.

Ratios	
First	3.50:1
Second	1.99:1
Third	1.00:1
Reverse	3.97:1

4-SPEED SYNCHRO-MESH

Manually operated 4-speed transmission with full synchronization of all forward gears. Floor mounted gearshift lever.

Ratios	RPO 651	RPO 652
	Corvair Sedan, Coupe, and Station Wagon Models	Greenbrier Sports Wagon
First	3.65:1	3.65:1
Second	2.35:1	2.35:1
Third	1.44:1	1.44:1
Fourth	1.00:1	1.00:1
Reverse	3.66:1	3.66:1

POWERGLIDE—RPO 360 Sedans, Coupes, & Station Wagons, RPO 667 Greenbrier

2-speed three-element torque converter automatic transmission similar in principle to conventional Chevrolet and Chevy II Powerglide transmissions, but specifically engineered for transaxle drive. Instrument panel mounted

indicator and gearshift selector lever. Selector sequence: L-D-N-R. Accelerator actuated automatic downshift into low gear for extra passing power.

Torque Multiplication

Drive	4.73:1 to 1:1 range
Low and reverse	4.73:1 to 1.82:1 range

CLUTCH . . . for Corvair 3- and 4-Speed Transmission Power Teams

	80-hp Turbo-Air 145	102-hp Turbo-Air 145
Type	Diaphragm spring with single plate dry disk	
Spring Pressure (Effective pressure plate load—lbs.)	900-1075	
Disk Facing Material	Woven asbestos	
Disk Facing Outside Diameter (Inches)	8.0	
Disk Facing Total Area (sq. in.)	44.0	

Transmissions and Clutches

- 145-CU.-IN. AIR-COOLED 6
- TWIN CARBURETION WITH AUTOMATIC CHOKE
- HYDRAULIC VALVE LIFTERS
- SINGLE EXHAUST

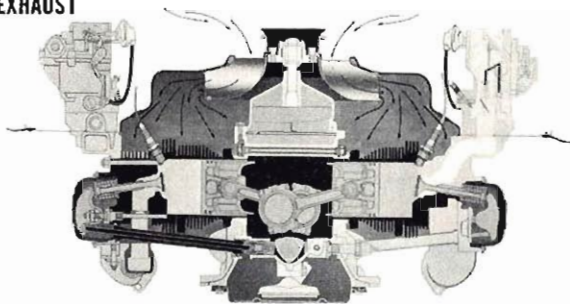
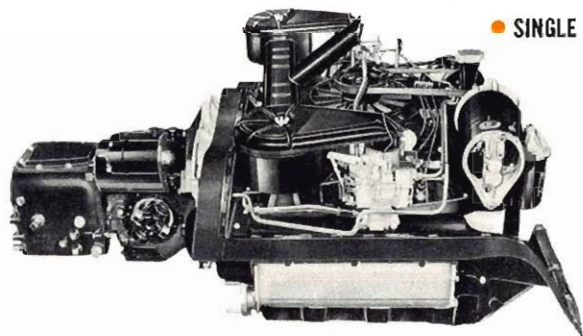
**MAJOR FEATURE DIFFERENCES****STANDARD 6****RPO 649**

Horsepower @ rpm

80 @ 4400*

102 @ 4400

Maximum torque (ft.-lbs.) @ rpm

128 @ 2300*

134 @ 2800-3000

Compression ratio

8.0:1*

9.0:1

Camshaft type

Economy contoured

Special performance

Bearing inserts

High quality

Premium quality

Exhaust pipe diameter

1.875"

2.0"

*In Monza models equipped with Powerglide: compression ratio—9.0:1, hp—84 @ 4400, torque—130 @ 2300

Engine Features

SPECIFICATIONS

BASIC DESIGN. Valve-in-head horizontally opposed six, 3.4375" bore x 2.60" stroke, 145-cubic-inch piston displacement. Precision-cast aluminum alloy crankcase and cylinder heads, cast alloy iron individual cylinders. Precision-cast wedge-type combustion chambers. Compression ratio: standard 6, 8.0:1 (9.0:1 on 900 Monza with Powerglide); RPO 649 engine, 9.0:1. Three-ring aluminum alloy pistons with offset piston pins and special steel struts to control expansion. Wear-resistant coated top and second ring, one-piece oil control ring. Forged steel connecting rods with piston pins clamped in upper end and replaceable lower bearings. Rugged forged steel crankshaft with four replaceable main bearings. High quality main and connecting rod bearing inserts (premium quality in Greenbrier and Super Turbo-Air engines). Flywheel: machined cast alloy iron with manual transmissions, pressed steel with Powerglide. Power plant mounted on rubber cushions, two front, one rear.

ELECTRICAL SYSTEM. 12-volt, with 40-ampere-hour battery and 30-ampere generator standard equipment (optional heavy-duty generator listed on page 36), protected by voltage and current regulator. Positive-shift starter with solenoid-

engaged drive pinion and overrunning clutch. Hermetically sealed ignition coil. Single-breaker distributor with combination centrifugal and vacuum spark advance. Non-metallic high-tension spark cables. Spark plugs: AC 46 FF with 80-hp engine, AC 44 FF with 84- and 102-hp engines. Rubber boots.

COOLING SYSTEM. Forced air type with thermostatically controlled air flow over fins formed on cylinder barrels and heads. Engine enclosed by sheet metal shrouds to direct air over engine components. Cooling controlled by thermostatically regulated air exhaust doors at rear of each lower shroud.

LUBRICATION SYSTEM. Controlled full-pressure type with oil cooler and full-flow oil filter. Refill capacity 4 quarts (5 with filter replacement). Gear type oil pump, with fixed intake, develops normal 45 p.s.i. oil pressure at 2000 engine rpm. Red oil pressure warning light on instrument panel. Road draft crankcase ventilation standard, special crankcase ventilation system optional at extra cost (RPO 242 or 243).

FUEL AND INDUCTION SYSTEM. Twin single-barrel carburetors with automatic choke and oil-

wetted polyurethane element air cleaners. Intake manifolds cast integral with aluminum cylinder heads. Mechanical pulsator-type fuel pump driven by crankshaft. Sintered fuel filter in each carburetor, fine-mesh fuel strainer in fuel tank. Electric fuel gauge. Fuel tank capacity 14 gallons (18.5 gallons on Greenbrier). Recommended fuel: regular with 80-hp, premium with 84- and 102-hp engines.

VALVE SYSTEM. Valve-in-head, with independent operating mechanism for each valve. Pressed steel rocker covers. Valve material: intake, carbon steel; exhaust, high alloy steel. Integral valve guides and seats machined in cylinder heads. Variable-pitch valve springs. Pressed steel rocker arms with ball and socket mounting. Tubular steel push rods actuated by quiet hydraulic valve lifters. Cast alloy iron camshaft, with wear-resistant coating, mounted on five aluminum crankcase bearings and driven from crankshaft by quiet gears.

EXHAUST SYSTEM. Single, with reverse-flow muffler. Cast iron exhaust manifolds fitted to three steel sleeves pressed into exhaust ports of cylinder head. Muffler ends zinc coated for durability. Aluminum-coated outer body cover over asbestos liner.

Engine Specifications

Corvair 900, 700, 500 Series . . .

MONOSTRUT BODY BY FISHER . . .

4-Door Sedan body illustrated . . . other models basically similar except for roof or other specific structure.

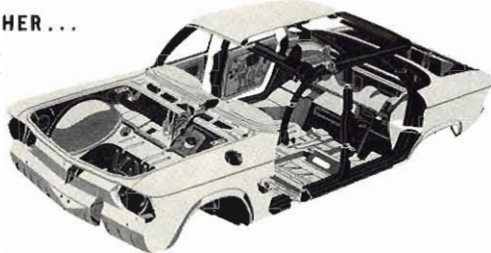

BODY STRUCTURE

Fully unitized, all-welded heavy-gauge steel body construction with:

- Rugged box-section design roof rails, windshield and rear window headers, door and roof pillars.
- Heavy-gauge steel roof panel with single flanged-channel lateral reinforcement on Sedan models . . . three on Station Wagon.
- High-strength double-walled cowl unit-welded to instrument panel, front body panel, and dash panel.
- Deeply ribbed and contoured floor panel with massive underbody-reinforcing box-section crossmembers.
- Extra-rugged heavy-gauge steel double box-section body sills and extensions.
- Integrated, extra-rigid front and rear body structures.
- Double-panel door, front luggage compartment lid, rear deck lid, and station wagon liftgate construction.
- Fully counterbalanced luggage compartment lid and station wagon liftgate.
- Structural components and body panels protected from corrosion by various primer coatings, zinc coatings, and anti-rust compounds. Selected structural members heavily zinc-coated before assembly.
- All exposed undersurfaces further protected with corrosion-resisting paint.

SOUND INSULATION

- Asphalt-impregnated felt blanket roof and luggage compartment lid insulation on all models, and on engine compartment lid of Sedans and Coupes. Station Wagon engine access door in cargo floor insulated with special fiber glass blanket.
- Sedan and Coupe interiors insulated from engine compartment by inch-thick fiber glass blanket on engine side of rear bulkhead, and by thick jute blanket, fiber board and fibrous mat blanket on passenger side.
- Asphalt-impregnated felt blanket floor insulation under seats, plus heavy jute mat underneath floor covering.
- Spray-on sound deadening compound on inner surfaces of door outer panels and sidewall panels.
- Asphalt-impregnated fiber undercoating on underbody and wheel housings.

WEATHERSEALING

- Vinyl-covered rubber windlace around door openings.
- Weather-tight formed rubber windshield, rear window, and station wagon liftgate window seals.
- Rubber-fabric glass channel and window sill seals.
- Double-sealing door and liftgate formed rubber seals.
- Formed rubber luggage compartment lid seal.
- Special body seam and joint sealing compounds.

PLUS . . . ALL THESE QUALITY FEATURES

- High-Level ventilation system
- Built-in forced-air heater and defroster system
- Parallel-action electric windshield wipers
- Safety Plate Glass in every window
- Magic-Mirror acrylic lacquer finish
- Single-key lock system
- Lined stowage compartment behind rear seat on all Sedan and Coupe models
- Locking front luggage compartment
- Roomy Station Wagon cargo area
- Friction-type ventipanes
- Triple-safe door locks
- Pushbutton-type outside door handles
- Weather-shielded key locks
- Color-keyed interior trim
- Extra-quality interior features and appointments
- Full-view instrument panel with complete complement of instruments and controls, cigarette lighter, and locking glove compartment

Corvair 900, 700, 500 Series Body Features

Corvair 900, 700, 500 Series Chassis Specifications . . .

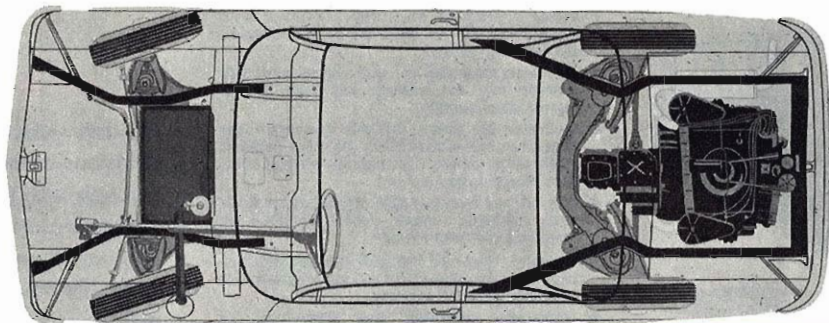

QUADRI-FLEX 4-WHEEL INDEPENDENT SUSPENSION—Front: Coil spring spherical joint independent suspension with long and short control arms. Concentric springs and shock absorbers diagonally located between upper and lower control arms. Quiet, low-friction non-metallic spherical joint liners automatically adjust for wear and contribute to easier turning. Built-in anti-dive control helps keep car level during severe stops. Rear: Swing-axle rear suspension with universal joint attachment to axle permits independent movement of each rear wheel. Concentric coil springs and shock absorbers mounted between upper crossmember and lower control arms. Lower control arm attached to crossmember at rubber-bushed pivot points. Crossmember bolted to body and insulated by heavy rubber cushions prevents transference of road sounds and vibration.

SHOCK ABSORBERS—Direct, double-acting, permanently sealed hydraulic shock absorbers specifically engineered to complement suspension systems for improved ride control. Both front and rear shock absorbers centrally located within coil springs.

TRANSAXLE DRIVE—Transmission and rear axle combined into one compact unit . . . combines with engine to form rear-mounted Unipack Power Team. Hypoid-type axle connected to axle shafts by universal joints. Flow of torque from engine and transmission to axle accomplished by unique 2-unit driveshaft design. 3- and 4-speed transmissions and axle share a common lubrication system. Capacities are: 3-speed—2 pints, 4-speed—3 pints, rear axle—3 pints. Powerglide transmissions have separate lubrication system apart from rear axle. For specific information see Feature Details section.

STEERING—Balanced, symmetrical system with relay-type linkage and high-ratio Ball-Race steering gear. Overall steering ratio—23.5:1. Steering wheel diameter—16". Wheel turns stop to stop—4.60.

SAFETY-MASTER BRAKES—Air-cooled Safety-Master 4-wheel hydraulic brake system basically similar to that of conventional Chevrolet. Brake drum diameter—9". Lining width—front and rear: 1.75". Total effective lining area—126.14 sq. in. Braking distribution—front: 46%, rear: 54%.

Full molded asbestos composition linings bonded to brake shoes. Composite steel and cast iron brake drums with wide cooling flanges for rapid heat dissipation. Parking brake operation by pistol-grip control lever to left of steering column. Optional sintered-metallic brake linings available for unusually severe, heavy-duty operation.

MUFFLER—Long-life reverse-flow type muffler constructed of highly corrosion-resistant materials discharges exhaust gases with minimum sound and power-robbing back pressure. For specific details see page 31, Corvair section or Feature Details section.

WHEELS AND TIRES—Welded steel short-spoke disc 13" diameter, 5.5" rim width wheels with special cooling slots for circulating air around brakes. Black sidewall highway rayon 4-ply rating tires standard on all 700 and 500 series models. White sidewall tires standard on Monza models . . . optional on all 700 and 500 models. All wheels and tires statically balanced for smooth, quiet operation and longer tire life. For tire sizes see model specifications.

Corvair Chassis Specifications

Greenbrier Sports Wagon

UNITIZED VAN-TYPE BODY...



BODY STRUCTURE

Fully unitized heavy-gauge steel van-type body construction. Basic body structure comprised of five all-steel substructures solidly welded to form an integrated unit of exceptional strength and rigidity with extra-large load capacity. Heavy-duty design features include:

- Heavily ribbed and contoured floor panel assembly reinforced with massive crossmembers and lateral reinforcing sill structures. Unique drop-center floor increases cargo capacity, contributes to easier loading.
- Full-length combination box- and hal-section underbody-reinforcing sills. Box-section front sill integrated with intermediate and rear sills through heavy-duty shear plates and lateral supports.

- High-strength double-walled front end structure unit-welded to instrument panel, floor, box-section windshield header, and full height box-section windshield and door hinge pillars.
- Extra-heavy gauge steel roof panel with welded-on full-perimeter rails, and reinforced with seven flanged-channel lateral supports.
- Front door lock pillars, right-side double-side door hinge pillars, side window pillars, and body side panels solidly welded to form rigid, high-strength side structures integrating floor and roof.
- Body side and door outer panel styling features sculptured, full-length concave grooves for distinctive appearance and greater rigidity.
- Integrated, extra-rigid rear body structure with box-section rear door opening and roof support pillars joins sides, roof, and floor structures.
- Double-panel construction front, double-side, and double-rear doors.
- Corrosion-resisting high zinc content chromate primer applied to entire lower underbody. Wheelhouse areas protected with spray-on undercoating.

SOUND INSULATION

- Engine access door in rear cargo floor insulated with special fiber glass blanket.
- Special spray-on sound deadening compound on inner surfaces of door outer panels and sidewall panels.
- Asphalt-impregnated felt blanket floor insulation under seals, plus jute mat underneath floor covering.
- Spray-on asphalt-impregnated fiber sound deadening on underbody and wheel housings.

WEATHERSEALING

- Vinyl-covered rubber windlace around door openings.
- Weather-tight formed rubber windshield, stationary side window, and double-rear door window seals.
- Rubber-fabric front door and double-side door glass channel and window sill seals.
- Special body seam and joint sealing compound.

Greenbrier Body Features

PLUS... ALL THESE QUALITY FEATURES

- High-Level ventilation system
- Parallel-action electric windshield wipers
- Extra-large Safety Plate Glass windshield
- High quality synthetic enamel finish
- Single-key lock system
- Friction-type ventipanes
- Wide-opening front, double-right side and double-rear doors
- 2-position double-side and double-rear door checks
- Versatile 3-position, removable second seat
- Adjustable front seat with adjustable backrest
- Weather-shielded key locks
- Roll-down front door and side windows
- Quality interior features and appointments
- Full-view instrument panel with complete complement of instruments and controls and locking glove compartment

Greenbrier Sports Wagon Chassis Specifications . . .

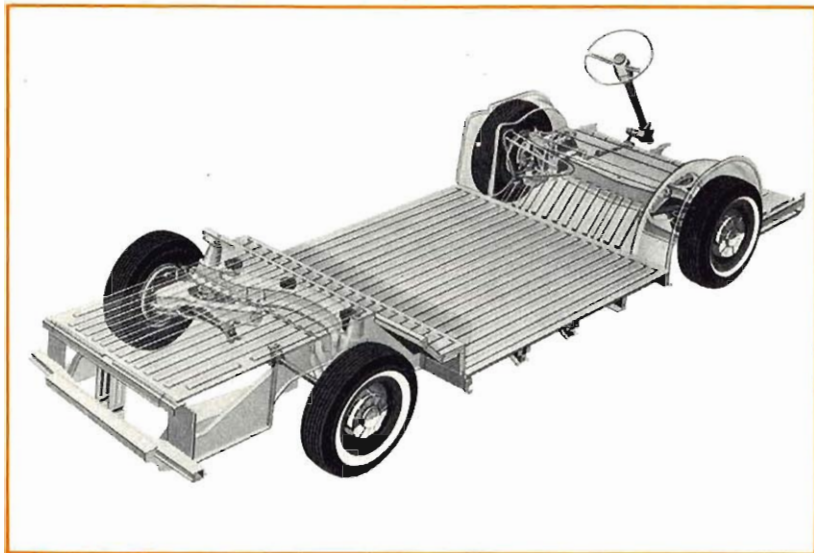

QUADRI-FLEX 4-WHEEL INDEPENDENT SUSPENSION—Front: Coil spring spherical joint suspension with long and short control arms. Concentric springs and shock absorbers diagonally located between upper and lower control arms. Quiet, low-friction non-metallic spherical joint liners automatically adjust for wear and contribute to easier turning. Rear: Swing-axle rear suspension with universal joint attachment to axle permits independent movement of each rear wheel. Concentric coil springs and shock absorbers mounted between upper crossmember

and lower control arms. Lower control arm attached to crossmember at rubber-bushed pivot points. Crossmember bolted to body-frame structure and insulated by heavy rubber cushions prevents transference of road sounds and vibration to body.

STEERING—Balanced, symmetrical system with relay-type linkage and high-ratio Ball-Race steering gear. Overall steering ratio—23.0:1. Steering wheel diameter—17"

SHOCK ABSORBERS—Direct, double-acting, permanently sealed hydraulic shock absorbers specifically engineered to complement suspension systems for improved ride control. Both front and rear shock absorbers concentrically located within coil springs.

TRANSAXLE DRIVE—Transmission and rear axle combined into one compact unit . . . combines with engine to form rear-mounted Unipack Power Team. Hypoid-type axle connected to axle shafts by universal joints. Flow of torque from engine and transmission to axle accomplished by unique 2-unit driveshaft design . . . for specific information see Feature Details section.

SAFETY-MASTER BRAKES—Air-cooled Safety-Master 4-wheel hydraulic brake system basically similar to regular Corvaair. Brake drum diameter—11". Lining width—front and rear: 2.00". Total effective lining area—153.9 sq. in. Braking distribution—front: 56%, rear: 44%. Full molded asbestos composition linings bonded to brake shoes. Composite steel and cast iron brake drums with wide cooling flanges for rapid heat dissipation. Parking brake operation by pistol-grip control lever to left of steering column.

MUFFLER—Long-life reverse-flow type muffler constructed of highly corrosion-resistant materials discharges exhaust gases with minimum sound and power-robbing back pressure. For specific details see page 31, Corvaair section or Feature Details section.

WHEELS AND TIRES—Welded steel short-spoke disc 14" diameter, 5.0" rim width wheels with special cooling slots for circulating air around brakes. Black sidewall highway rayon 4-ply rating tires standard . . . while sidewall tires optional. All wheels and tires statically balanced for smooth, quiet operation and longer tire life. For tire size see model specifications.

Greenbrier Chassis Specifications

Corvair Factory-Installed Options For all models except as otherwise indicated.

ENGINES

RPO 649 102-HP TURBO-AIR 145—All models except Greenbrier. 145 cu. in., 9.0:1 compression ratio. Includes special camshaft and valve springs, recalibrated carburetor, and larger exhaust system.

TRANSMISSIONS

RPO 380 CORVAIR POWERGLIDE

RPO 887 CORVAIR POWERGLIDE—For Greenbrier.

RPO 651 4-SPEED SYNCHRO-MESH

RPO 652 4-SPEED SYNCHRO-MESH—For Greenbrier.

AXLE RATIOS

RPO 693 3.55:1 AXLE RATIO—For Coupes and Sedans. Standard in Station Wagons, and with 102-hp Turbo-Air 145 engine and Corvair Powerglide.

RPO 682 3.89:1 AXLE RATIO—For all power teams in all models (Standard in Greenbrier).

CORVAIRS OTHER THAN GREENBRIER

FOA 114 AIR CONDITIONER, DE LUXE—For 4-Door Sedans and Club Coupes.

FOA 103 MANUAL RADIO AND ANTENNA

FOA 104 PUSHBUTTON RADIO AND ANTENNA

RPO 398 SOFT-RAY TINTED GLASS—All windows, or windshield only.

RPO 664 FOLD-DOWN REAR SEAT—Standard in all Monzas and 700 Station Wagon.

RPO—As Listed BUCKET FRONT SEATS—All vinyl—For Monza 4-Door Sedan and Station Wagon. Color-keyed—Fawn, RPO 769; Aqua, RPO 719; Red, RPO 785; Blue, RPO 736; Gold, RPO 799; Black, RPO 715.

FOA 120 COMFORT AND CONVENIENCE EQUIPMENT—For Monza models includes outside rearview mirror, 2-speed electric windshield wiper and pushbutton washer. For all other models includes above equipment plus back-up lights and glove compartment light.

RPO 248 REAR DOOR ARMRESTS—For Corvair 700 4-Door Sedan and Station Wagon. Standard on Monza.

RPO 427 INSTRUMENT PANEL PAD

FOA 117 WHEEL COVERS—Set of four—Standard on Monza.

FOA 133—SIMULATED WIRE WHEELS—Set of four.

RPO 681 THINLINE WHITEWALL TIRES—6.50 x 13 4-p.r.—For 4-Door Sedans and Club Coupes.

RPO 449 THINLINE WHITEWALL TIRES—7.00 x 13 4-p.r.—For Station Wagons only.

RPO 384 SPARE WHEEL AND TIRE LOCK—For 4-Door Sedans and Club Coupes.—Not available with FOA 114.

RPO 242 SPECIAL CRANKCASE VENTILATION SYSTEM—(California type).

RPO 480 POSITRACTION REAR AXLE—Choice of 3.55:1 or 3.89:1 ratios in all models, also 3.27:1 except in Station Wagon or with 102-hp Turbo-Air 145 engine and Powerglide.

RPO 686 SINTERED-METALLIC BRAKE LININGS
RPO 686 HEAVY-DUTY FRONT AND REAR SUSPENSION—Includes front and rear springs and shock absorbers, front stabilizer bar, and rear axle rebound straps. For Club Coupes and Sedans.

FOR GREENBRIER

FOA 123 MANUAL RADIO AND ANTENNA

FOA 138 HEATER-DEFROSTER—Forced-air type.

FOA 128 HEATER-DEFROSTER—Aircraft-type gasoline heater.

RPO 431 GREENBRIER DE LUXE EQUIPMENT—Includes red, green, turquoise, or fawn color-keyed upholstery, vinyl sidewall panels, vinyl-coated rubber floor

mats; vinyl tire cover; vinyl headlining between roof bows; two-tone instrument panel and steering wheel; glove compartment door bright trim panel; cigarette lighter; dual sun visors; front armrests; rear ashtrays; rear dome light; foam-cushioned seats and seat backs; red plastic inserts at taillights; and bright metal hub caps, bumpers, and windshield trim.

RPO 268 REAR (THIRD) SEAT (with RPO 431 includes rear armrests).

RPO 645 DOUBLE LEFT-HAND SIDE DOORS

RPO 370 LAMINATED GLASS—Front door windows.

RPO 393 CHROME-PLATED HUB CAPS AND FRONT AND REAR BUMPERS—Included in RPO 431 De Luxe Equipment.

FOA 132 WHEEL COVERS—Set of four.

RPO 210 OUTSIDE REARVIEW MIRROR

RPO 647 WHITEWALL TIRES—7.00 x 14 4-p.r.

RPO 648 BLACKWALL TIRES—7.00 x 14 6-p.r.

RPO 674 WHITEWALL TIRES—7.00 x 14 6-p.r.

RPO 355 2-SPEED ELECTRIC WINDSHIELD WIPER—Includes Pushbutton Windshield Washer.

RPO 243 SPECIAL CRANKCASE VENTILATION SYSTEM—(California type).

RPO 255 HEAVY-DUTY FRONT SPRINGS

RPO 213 HEAVY-DUTY FRONT SHOCK ABSORBERS

RPO 481 POSITRACTION REAR AXLE—3.89:1 ratio.

RPO 420 TAXICAB EQUIPMENT

ALL CORVAIRS INCLUDING GREENBRIER

RPO 850 HEAVY-DUTY GENERATOR—35-Ampere, low cut-in.

FOA 148 SEAT BELT—Specify one or two belts.

Corvair Dealer-Installed Custom Feature Accessories

... for all Corvair and Greenbrier models except as indicated.

	PART NO.		PART NO.		PART NO.
Accelerator Pedal Cover.....	985260	Heater and Defroster—Forced-Air De Luxe		Radio and Antenna—Pushbutton	
Air Conditioner—De Luxe		Greenbrier only—Standard on all other Models	985340	(Except Greenbrier).....	985155
(Sedan and Coupe Models only).....	985146	Heater and Defroster—Gasoline Type		Rear Seat Luggage Cover.....	988363
Antenna—Manual—Front		All Models except Greenbrier.....	985342	Rearview Mirror—Inside—Non-Glare.....	985152
All except Greenbrier.....	985055	Greenbrier.....	985344	Rearview Mirror—Outside—Body Mount	
Greenbrier.....	988329	Lamp—Dome (Greenbrier only).....	988346	Sedan, Coupe, and Station Wagon Models.....	985169
Armrests—Rear (Standard on Monza 4-Door		Lamp—Glove Compartment		Greenbrier.....	985285
Sedan—not available on Club Coupes or		(700, 500, and Greenbrier).....	985273	Seat Belt—Front.....	985357
Greenbrier)		Lamp—Luggage Compartment.....	985246	Seat Belt—Rear (Except Greenbrier).....	985180
Fawn—985308, Aqua—985310, Red—985312,		Lamp—Safetylight (Greenbrier only).....	988335	Tissue Dispenser.....	985339
Blue—985313		Lamp—Spot—Portable		Tissue Dispenser and Litter Container.....	985275
Cigarette Lighter (Greenbrier only).....	985237	(Connects to Cigarette Lighter).....	987112	Tool Kit.....	988032
Clock—Electric.....	985329	Lamp—Underhood		Ventshade	
Compass—Illuminated.....	985002	(Except Greenbrier and Station Wagons).....	985217	2-Door Models.....	985167
Cover—Plastic—Front Seat		Lamps—Back-Up (Standard on Monza Models.		4-Door Models.....	985166
All 2-Door Models except Monza Club Coupe..	989287	Not available on Greenbrier)		Station Wagon.....	985168
All 4-Door Models except Monza with Optional		Sedans and Coupes—except 4-Speed		Greenbrier.....	985025
Bucket Seats.....	988288	Transmission.....	985183	Visor—R. H. Sun (Greenbrier).....	985238
Door Edge Guards		Station Wagon—except 4-Speed Transmission.	985184	Wheel Covers—Full—Set of Four	
2-Door Models.....	988422	Adapter for 4-Speed Transmission Equipped		Standard on Monza. Not available on Greenbrier	985257
4-Door Models.....	988082	Models.....	985072	Wheel Cover—Wire (Except Greenbrier).....	985373
Floor Mat—De Luxe Full-Width Front		Lamps—Courtesy		Windshield Washer—Pushbutton	
(Except Greenbrier)		500 Series.....	985298	All except Greenbrier.....	985236
White—985095, Aqua—985245, Gold—985287,		700 and 900 Series.....	985299	Greenbrier.....	985304
Black—985094, Blue—985243, Red—985099,		License Plate Bezel.....	985325	Wiring Harness—For Radio/Heater Installation	
Fawn—985244		Litter Container.....	985276	All except Greenbrier.....	985086
Floor Mat—Contour Front (Except Greenbrier)		Lock—Rear Door Safety (Except Greenbrier)...	985295	Greenbrier.....	988350
White—985018, Aqua—985242, Gold—985288,		Lock—Spare Tire.....	985113	GREENBRIER SPECIAL CUSTOM FEATURES... see illustrations pages 26-27	
Black—988295, Blue—985240, Fawn—985241		Luggage Carrier—Roof		Screens—Side Windows—Set of Four.....	985100
Gas Filler Cap—Locking		4-Door Sedans.....	985056	Tent Unit, 8' x 10' x 6".....	985101
All except Greenbrier.....	988270	Station Wagons.....	985250	Car Top Sleeper.....	985102
Greenbrier.....	988277	Greenbrier.....	988398	Camper Unit.....	985103
Gas Filler Door Guard (Except Greenbrier).....	988274	Luggage Carrier Cover		Cargo and Baggage Net.....	985104
Guard—Front or Rear Bumper		4-Door Sedans.....	985300	Drawer Unit—Underseat.....	985105
All Sedan, Coupe, and Station Wagon Models.	988203	Greenbrier.....	985314	Shelter Unit.....	985106
Greenbrier—Painted.....	985070	Parking Brake Warning Light.....	985333	Table Unit.....	985107
Greenbrier—Chrome.....	988373	Radio and Antenna—Manual		Bed—Child.....	985359
Hazard Flasher Switch (Greenbrier only).....	985327	Sedan, Coupe, and Station Wagon Models.....	985154		
		Greenbrier.....	985202		

Options and Accessories