

# SECTION 7

## ENGINE TUNE-UP

### INDEX

	<i>Page</i>		<i>Page</i>
General Description .....	7-1	Vacuum Diaphragm Adjustment.....	7-4
Maintenance and Adjustments.....	7-1	Choke Adjustment.....	7-5
Distributor Points.....	7-1	Unloader Adjustment.....	7-6
Blower Belt Tension.....	7-1	Crankcase Ventilation.....	7-6
Carburetor Synchronization.....	7-1	Tune-Up Specifications.....	7-6
Fast Idle Cam Clearance.....	7-4	Turbo-Super Charger Tune-Up.....	Sect. 9

## GENERAL DESCRIPTION

Engine tune-up procedures for 1964 change from 1961 due to the following changes in design:

1. A new distributor provides easier servicing.
2. An automatic choke system provides more evenly controlled carburetion during warmup.

Only the procedures that differ from 1961 will be described here with a tune-up specifications table on the last page. Refer to the 1961 shop manual for other procedures.

## MAINTENANCE AND ADJUSTMENTS

### REPLACE DISTRIBUTOR POINTS AND CONDENSER

1. Loosen hold-down screws and remove cap.
2. Remove rotor and dust shield.
3. Lift off primary and condenser wire leads at clip.
4. Remove condenser bracket screw and condenser.

5. Remove contact point hold-down screw and remove points as a unit.
6. Reverse Steps 2-4 to install.

**NOTE: Primary and condenser leads must be installed between insulator and contact point spring arm.**

7. Adjust points to .019" new or .016" used (fig. 1) and lock stationary point. Check arm spring tension.
8. Rotate cam lubricator wick ½ turn.
9. Install dust shield and rotor, then install distributor cap and tighten screws.

**NOTE: Cap must be installed with notch to vacuum advance lever opening on housing.**

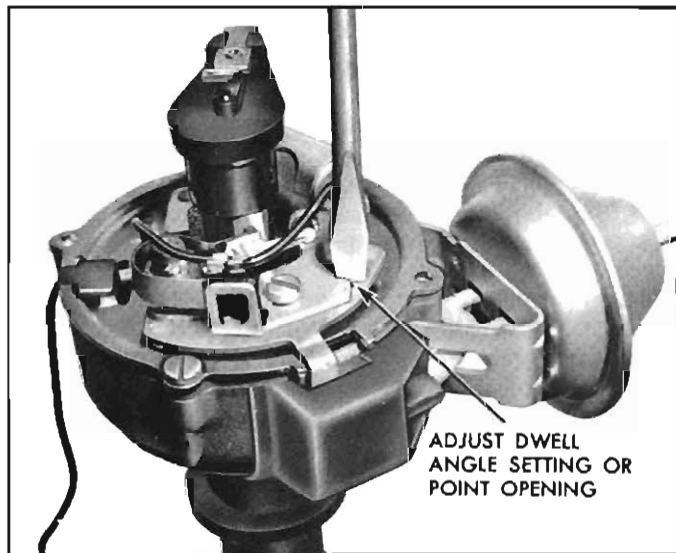

Fig. 1—Point Adjustment

### BLOWER BELT

Blower belt removal and replacement does not change but the methods of checking tension are as follows:

1. Use a strand tension gauge (fig. 2) and adjust idler pulley to give a reading of 75 ± 5 lbs. on new belts and 55 ± 5 lbs. on used belts.

### CARBURETOR SYNCHRONIZATION

#### 1. Initial Adjustments (Refer to Figure 3)

Perform the following adjustments on each car-

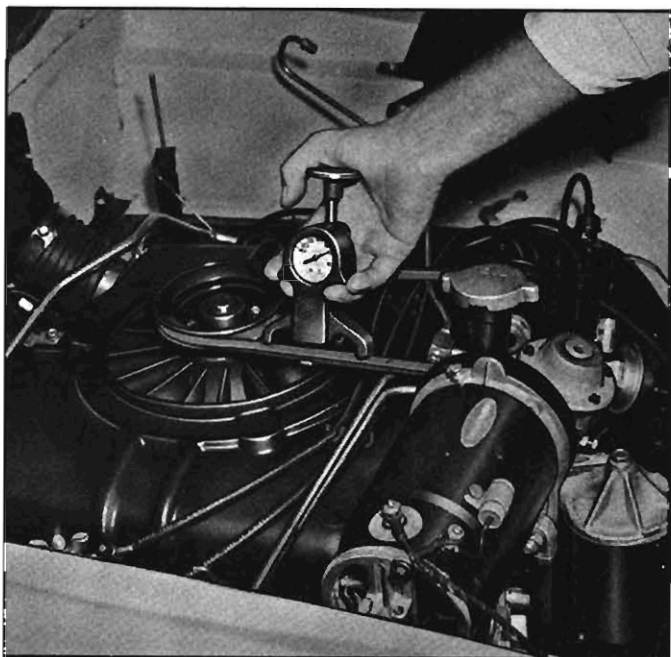

Fig. 2—Check Belt Tension

buretor, in sequence, with both throttle rods disconnected at the cross-shaft, choke control rods disconnected at choke levers and with engine off.

- a. Back idle speed screw away from throttle lever. Open the choke valve so throttle lever does not ride fast idle cam. Place a .003" feeler gauge between idle speed screw and throttle lever. Turn the screw until it just contacts the gauge and then turn 1½ more turns to set the throttle valve.

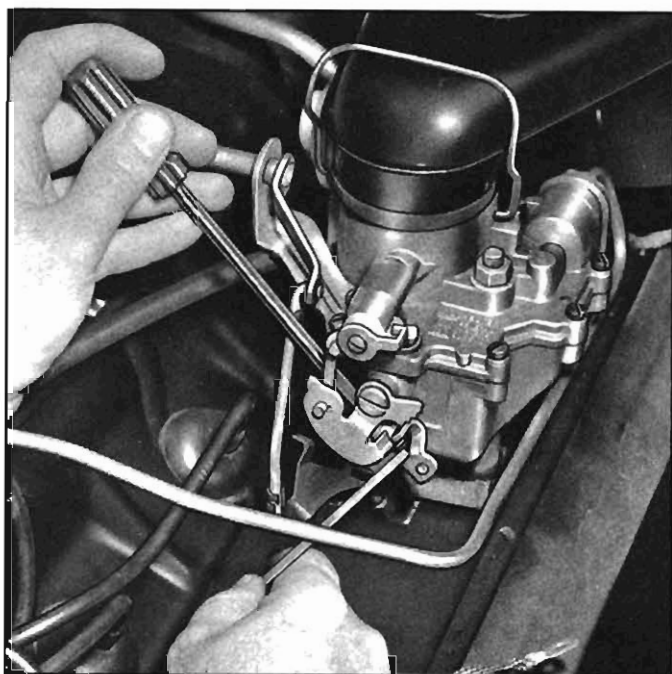

Fig. 3—Idle Adjustments

- b. Turn idle mixture screw lightly to its seat and back out 1½ turns.

**CAUTION:** Do not turn idle mixture screws tightly against seats or damage to needle and seat will result.

## 2. Connect Throttle Rods as Follows:

(Refer to Figure 4)

- a. Right Carburetor—Connect throttle rod to carburetor cross-shaft lever using retainer clip.
- b. Left Carburetor—Rotate cross-shaft (with accelerator rod) to ensure positive closing of right carburetor throttle valve. Adjust throttle rod length in swivel until rod freely enters hole on carburetor cross-shaft lever, then shorten rod one more turn in swivel. Secure rod with retainer clip.

**NOTE:** It may be necessary to hold the choke valve open so fast idle cam is clear of throttle lever.

**NOTE:** The carburetors are now mechanically synchronized. Any further idle speed or mixture adjustment must be duplicated on both carburetors.

## 3. Preliminary Curb Idle Speed and Mixture Adjustment

**NOTE:** Always check crankcase ventilation valve or orifice prior to adjusting idle. (See Crankcase Ventilation—Page 7-6).

- a. Start engine and normalize.
- b. Check timing.
- c. Connect vacuum gauge to adapter (fig. 4) on vacuum balance tube. (Remove transmission vacuum line on automatic transmission and cap on synchromesh from balance tube adapter.)
- d. Connect tachometer to engine.
- e. Adjust curb idle speed (duplicate adjustment on both carburetors) to attain approximate idle speed shown in chart for each engine. Adjust idle mixture screws on both carburetors to obtain peak steady vacuum at given idle speed.
- f. Remove vacuum gauge and close adapter as required for given transmission model.

## 4. Carburetor Balance—Vacuum Check

**NOTE:** Ordinarily carburetors are satisfactorily synchronized at this point, and Step 4 is merely a vacuum test comparing the two banks.

- a. Remove choke diaphragm hose from each carburetor base adapter and connect vacuum gauge to the adapter. (Best results can be obtained using 2 equally calibrated gauges.)

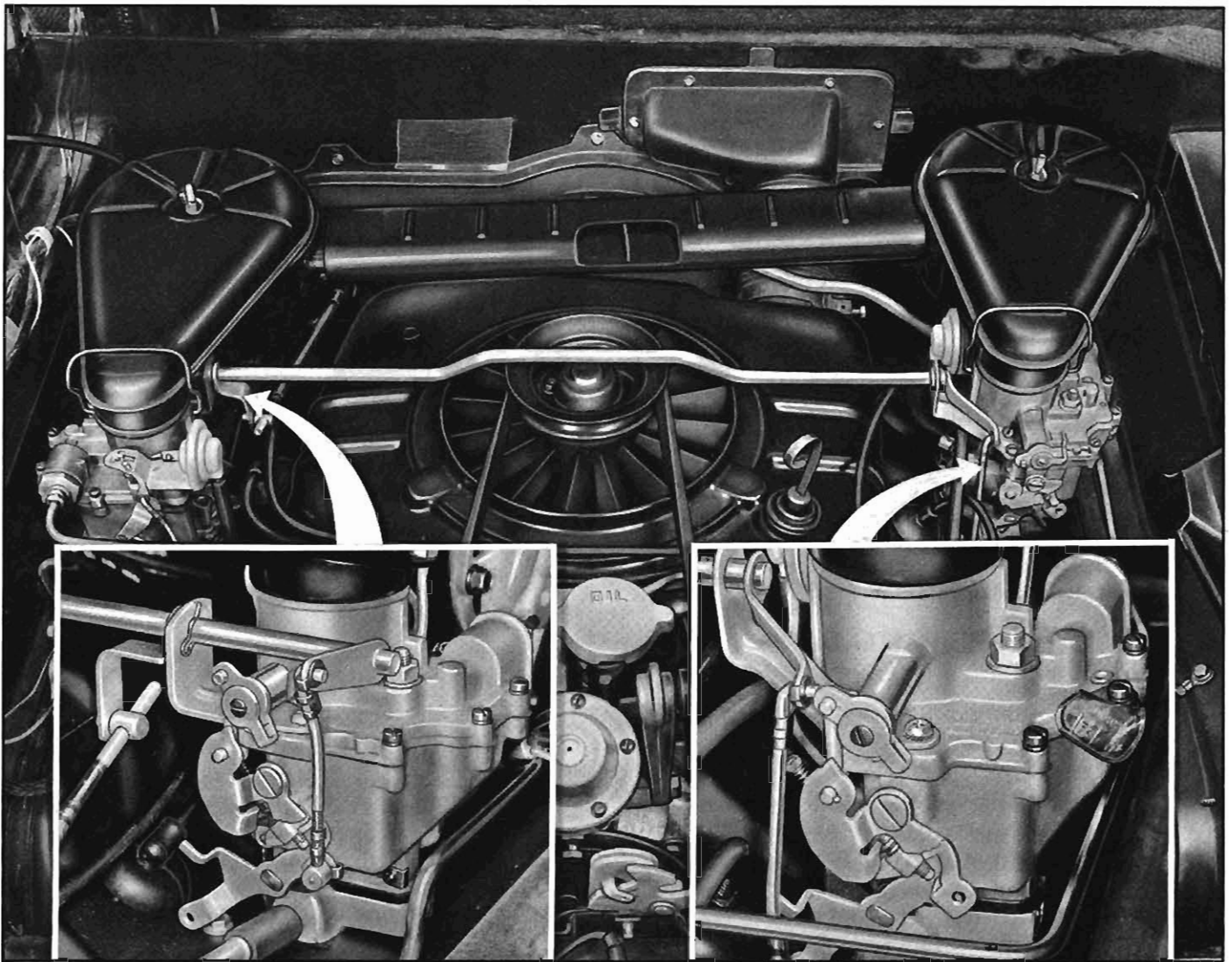

Fig. 4—Cross-Shaft and Carburetor Linkage

**CAUTION:** Do not turn tubing in carburetor body.

**NOTE:** One gauge can be used by constructing a "T" line to both carburetors from the gauge. Pinch hose closed between gauge and one carburetor and read vacuum of opposite carburetor.

- b. Operate engine at idle speed. Check vacuum at each carburetor and note difference. If difference is one inch or less, the carburetors are satisfactorily synchronized. If difference is more than one inch, adjust left carburetor throttle rod one turn (up to increase left carburetor vacuum and down to decrease) and recheck vacuum readings. Make the adjustment by disconnecting rod at cross-shaft and rotating it in the swivel.

**NOTE:** It is preferable to have higher reading on right carburetor (spark advance side).

**CAUTION:** When making linkage adjustments, move the cross-shaft by grasping accelerator rod only. Do not open throttle by grasping other portions of linkage as this might upset geometry and synchronization.

- c. Remove gauge/or gauges and replace choke diaphragm hoses.

## 5. Final Curb Idle Speed and Mixture Adjustment Check

**NOTE:** Always make final Idle speed mixture adjustment with air cleaners installed.

- a. Replace air cleaners.
- b. Reconnect vacuum gauge to vacuum balance tube adapter.
- c. Read vacuum at idle speed.

If necessary, adjust curb idle speed and mixture screws to highest steady vacuum reading between 14-18 inches.

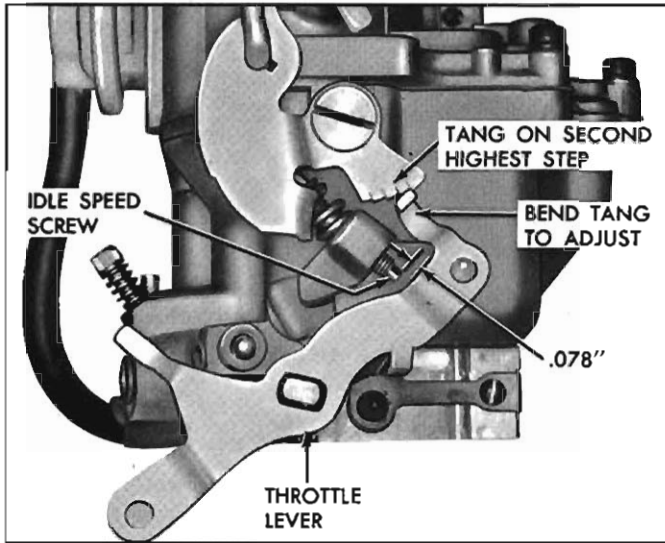

Fig. 5—Fast Idle Cam Clearance

**CAUTION:** Any necessary adjustment must be duplicated at each carburetor.

**ADJUST FAST IDLE CAM CLEARANCE**  
(Refer to Figure 5)

**NOTE:** This adjustment must be made after curb idle speed has been set.

- a. Stop engine.
- b. With throttle lever on second highest step of fast idle cam, bend tang to obtain .078" clearance between idle speed screw and throttle lever.
- c. Start engine and recheck speed as above.

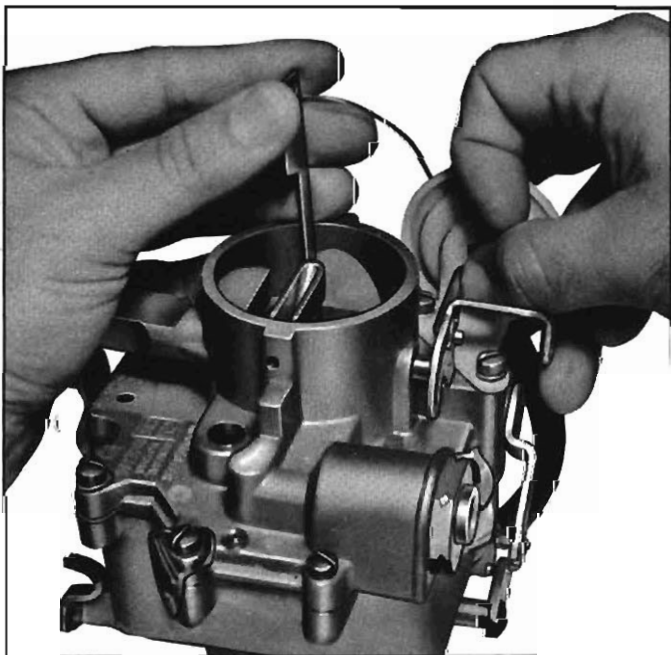

Fig. 6—Vacuum Diaphragm Adjustment

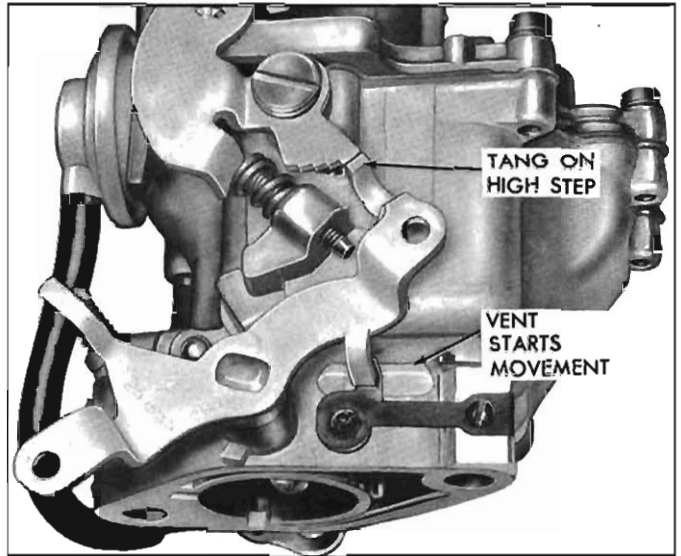

Fig. 7—Vapor Vent Adjustment

**VACUUM DIAPHRAGM ADJUSTMENT**  
(Refer to Figure 6)

- a. Hold vacuum diaphragm arm squarely against diaphragm.
- b. Measure clearance between lower edge of choke valve and wall of air horn. Clearance should be .180" to .195".
- c. If necessary to adjust, disconnect and bend diaphragm link.
- d. At this setting, throttle lever fast idle tang should rest on second highest step of fast idle cam. If not, adjust by bending outer choke shaft lever tang.

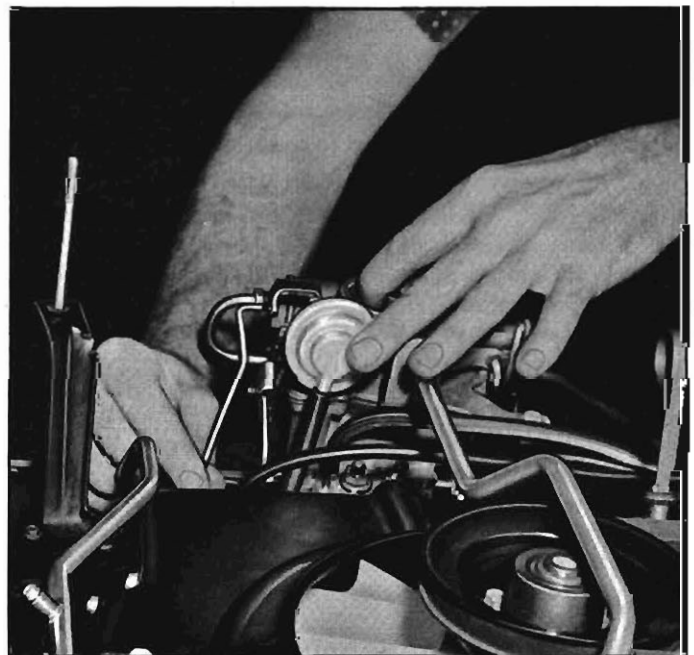

Fig. 8—Choke Control Rod Adjustment (R-10 Shown)

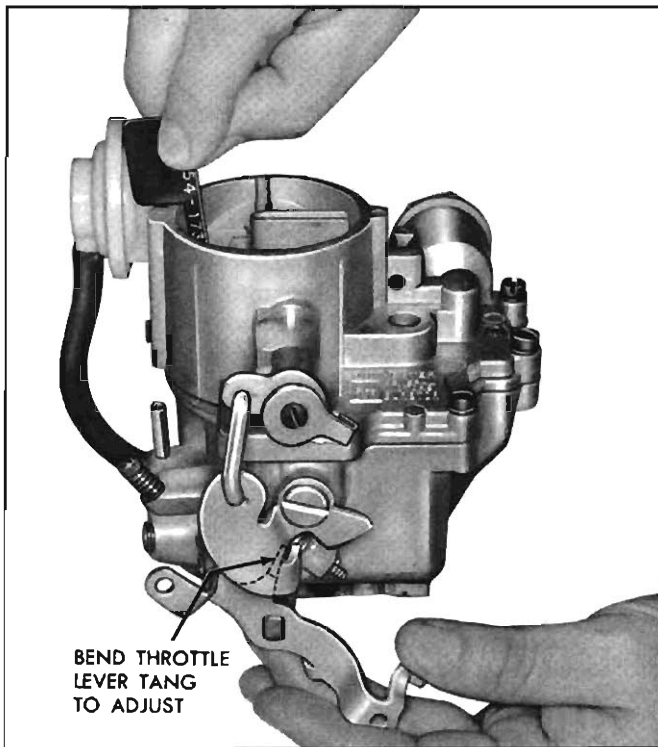

Fig. 9—Unloader Adjustment

**VAPOR VENT ADJUSTMENT (fig. 7)**

The vent should just start movement when idle screw is on high step of fast idle cam. The valve will then be open at curb idle setting. If necessary, adjust by bending throttle lever tang.

**NOTE:** It is hard to see this valve when carburetor is installed. A mirror will aid in making

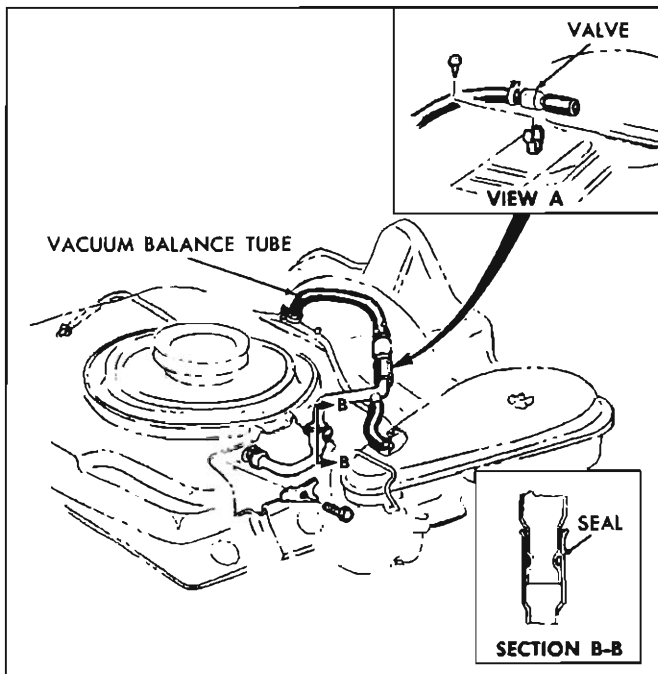

Fig. 10—Crankcase Ventilation

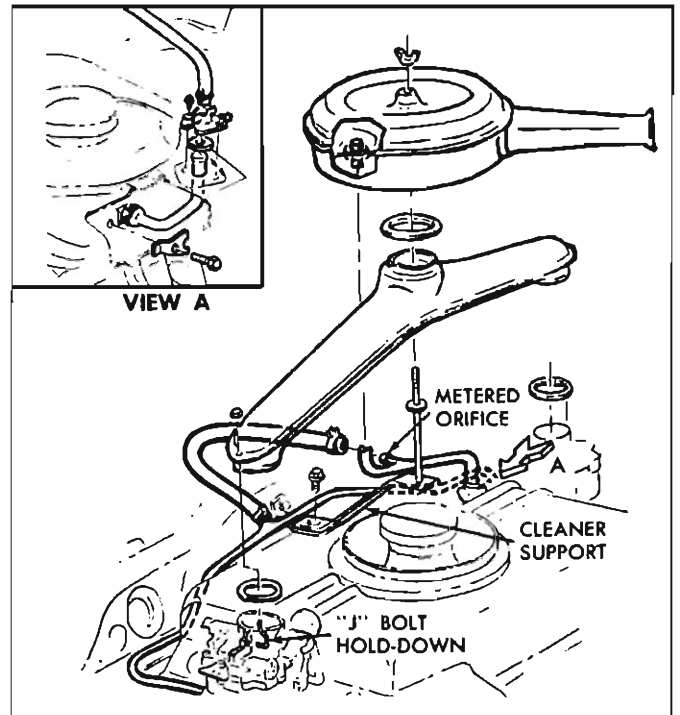

Fig. 11—Crankcase Ventilation—(Sedan)

this adjustment.

**CHOKE ADJUSTMENT (Refer to Figure 8)**

Perform adjustment with engine off.

1. Disconnect choke control rod at choke shaft lever.
2. Hold choke valve closed and, while holding the control rod up against the stop in choke thermostat bracket, adjust upper choke control rod until it freely enters hole in choke shaft lever.

**CAUTION:** To minimize the possibility of deforming the control rod while adjusting, always turn the vertical portion. Do not "crank" the rod using offset portion.

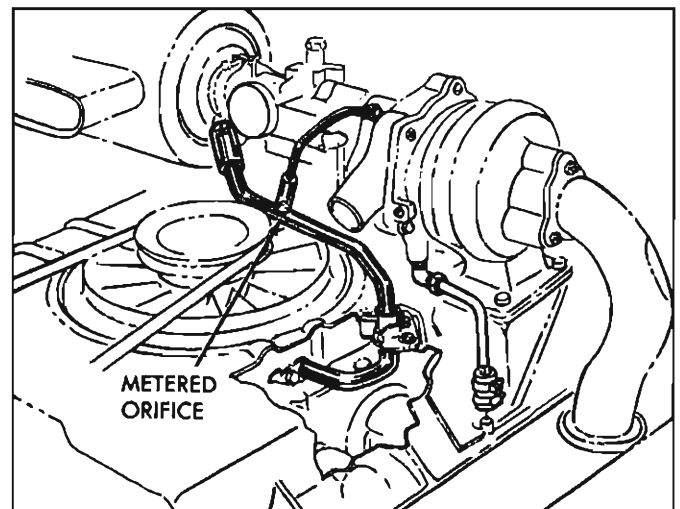

Fig. 12—Crankcase Ventilation—(Turbo-Charged)

## ENGINE TUNE-UP 7-6

3. Start engine and warm up—check choke position after warm up. Choke valve should be open and fast idle cam should clear the throttle lever.

### UNLOADER ADJUSTMENT (Refer to Figure 9)

Check unloader adjustment by holding throttle valve in wide open position and insert a .312" wire gauge between choke valve lower edge and wall of air horn. To adjust, if necessary, bend tang on throttle lever.

**NOTE: Unloader adjustment should be checked especially if it has been necessary to adjust the choke shaft outer lever tang during choke diaphragm link check.**

### POSITIVE CRANKCASE VENTILATION SYSTEM

All 1964 Chevrolet engines have either "positive" or "closed" positive ventilation systems utilizing manifold vacuum to draw fumes and contaminating vapors into the combustion chamber where they are burned. The crankcase ventilation system has an important function and should be understood and serviced properly.

In both positive and closed crankcase ventilation, air is drawn through the engine, through a regulating valve (or a fixed orifice) and into the manifold, drawing crankcase vapors and fumes with it to be burned.

The closed positive ventilation system draws the clean air from the carburetor air cleaner (figs. 10, 11, and 12) and has a non-vented oil filler cap.

Positive ventilation valves are designed specifically for each engine to control the amount of flow from the crankcase to the manifold. **VALVES SHOULD NEVER BE CHANGED FROM ONE SIZE ENGINE TO ANOTHER.**

The crankcase ventilation valve (or fixed orifice) will eventually plug and become ineffective and a dirty air cleaner element may affect ventilation operation, therefore, the valve should be tested and the air cleaner element serviced at regular intervals (See Section O).

The fixed orifice should be cleaned using a drill of the proper size (see tune-up chart for sizes).

Test the ventilation valve as follows:

1. Connect tachometer and vacuum gauge as for idle speed and mixture adjustment.
2. Set parking brake and start engine.
3. Disconnect ventilation hose at air cleaner side of valve, block opening of valve and read engine rpm change.
4. A change of less than 50 rpm indicates a plugged ventilation valve metering hole—replace the valve and adjust idle speed and mixture.

## TUNE-UP SPECIFICATIONS

ENGINE		TURBO-AIR	SUPER TURBO-AIR	TURBO-CHARGED ENGINE
Compression Pressure (See Note 1)		130 P.S.I.—Variation—20 P.S.I.		
Spark Plugs	Make and Number	AC-46FF	AC-44FF	AC-44FF—Std. AC-42FF—Competition
	Gap and Torque	.035" 15-20 Ft. Lbs.	.030"—15-20 Ft. Lbs.	
Ignition Distributor	Cam Angle	31°-34°		
	Point Gap	.019 New—.016 Used		
	Arm Spring Tension	19-23 ounces		
	Condenser	.18-.25 mfd.		
Ignition Timing	See Note 2	Synchromesh	2° BTDC	12° BTDC
		Automatic	10° BTDC	12° BTDC
Valve Lash	Inlet and Exhaust	Hydraulic—1 Turn to Center Lifter Plunger		
Fuel Pump	Pressure	4 to 5 lbs. @ Idle to 1000 RPM		
	Volume	1 Pint in 30 to 45 Seconds		
Engine Idle RPM	Automatic (In Drive)	500	500	—
	Synchromesh	500	600	850
Air Cleaners		See Note 3		
Blower Belt Adjustment		55 ± 5 lbs. (used) 75 ± 5 lbs. (new) using Strand Tension Gauge		
Carburetor		2 Rochester Model "H"		Carter YH Side Draft
Exhaust Damper Door Adjustment		Approx. 2 3/8" from door top to top of opening with control rod against bellows stop		
Crankcase Vent		.062 Metered Orifice or AC—CV584 Valve		.089" Metered Orifice

**NOTE 1—At cranking speed with all plugs removed and throttle wide open.**

**NOTE 2—With Vacuum advance disconnected.**

**NOTE 3—Paper Element—Check at each tune-up—Replace if clogged, Polyurethane (Turbo-charged)—Clean and Re-Oil at 6000 mile intervals.**