



the fifth wheel

Winner of the 2014 CORSA Tony Fiore Newsletter Competition

JULY 2015

[HTTP://WWW.CORVAIR.ORG/CHAPTERS/LVCC](http://www.corvair.org/chapters/lvcc)

ESTABLISHED 1976

Inside this issue

1963 Monza Interior,
Dick Weidner Collection 1

Next LVCC Meeting
Wednesday, July 22 1

Knoxville CORSA
Convention, by Al Lacki 2

Another Horizontal Cool-
ing Fan Kit for Porsche 4

June LVCC Meeting
Notes 4

Can This Corvair Be
Saved? 6

LVCC Classified
Ads 8

Three Big Pages of
Local Events 9

Das Awkscht Fescht
Reminder 11

Contact Info for LVCC
Officers & Dues Payment 11

The Great Phillipsburg
Auto Show Flyer 12



Next LVCC Meeting: Weds. July 22, 2015

Time 7:30 PM. Place: LANTA Community Center Meeting Room, 2nd Floor, 1060 Lehigh Street, Allentown, PA 18103. Latitude : 40.587607 | Longitude : -75.474405. Feel free to bring a guest. Don't get locked out! If you arrive late, the main door of the LANTA office building may be locked. This is for security purposes. But the facility is open around the clock, so ask one of the garage employees to direct you to the second floor.



The Fifth Wheel is published monthly by the Lehigh Valley Corvair Club (LVCC), Inc. We accept articles of interest to Corvair owners for publication. Classified advertising of interest to Corvair owners is available free of charge to all persons. Commercial advertising is also available on a fee basis. Please contact our newsletter editor, Allan Lacki for details.

LVCC is one of the many regional chapters of the Corvair Society of America (CORSA), a non-profit organization that was incorporated to satisfy the common needs of individuals interested in the preservation, restoration, and operation of the Chevrolet Corvair. LVCC caters to Corvair people who live in and around the Lehigh Valley Region of eastern Pennsylvania. This is a very special car club! LVCC dues are \$10 a year for CORSA members or \$15 a year for non-CORSA members.

Knoxville CORSA Convention

by Al Lacki

My daughter Karen and I went to the CORSA Convention in Knoxville last month. The weather was steamy-hot, but we had a lot of fun.

Karen was my co-pilot. She and I shared driving duties in my trusty Corvair, LeHeap, to and from the Convention. It was about a ten hour drive each direction. Oh, how I would have loved to have air-conditioning in the 'Vair. But with the vents open and all the windows down, we managed to survive the heat. One of the advantages of a rear-engine car is that all the engine heat is behind the interior of the car so it stays cooler inside.

Driving a Stick!

I had been teaching Karen how to drive the Corvair over the month prior to the Convention. She had never really driven a stick before and was still a bit rough shifting through the gears. But once she got it into fourth, she blasted along with the rest of the traffic on I-81 to Tennessee. I had the pleasure of being a passenger in my own car for half the journey.

Once we arrived there, we did plenty of events, including the Welcome Party, Newsletter Editors Meeting, Annual CORSA Membership Meeting, Economy Run, Rally, Autocross, Banquet and Car Display.

CORSA Meetings.

Bryan Blackwell of the Northern Virginia chapter did a commendable job conducting the Newsletter Editors Meeting, as did Ken Hand with the Annual CORSA Membership Meeting. Ken is the newly-elected President of CORSA, and he handled comments and suggestions from the floor with diplomacy and an open mind.

Moving Events.

The Economy Run on Thursday was a hoot! The route took us up - and I mean UP - the Foothills Parkway in the Great Smoky Mountain range. The views were hampered a bit by the hazy sky, but they were impressive nonetheless. And while it was necessary to take it easy on the accelerator pedal on the way up, we coasted with the car in neutral on the way down, thus saving gas. For a couple of stretches, I simply turned the engine off and rolled down the hill.

The Rally was held the same day, after the Economy Run, and it took a different route into the Smoky Mountains. It included a short stretch on the infamous "Tail of the Dragon" highway and a side trip into a hidden picnic area near a cool babbling brook in the shade.

There were a couple of checkpoints along the way, to keep everybody honest. This was a gimmick rally that required the co-pilot to answer sixty or so puzzling questions about sites along the way. Karen managed to answer all of them - correctly we believe - but like a bonehead, I made a U-turn during the mileage check, so my mileage correction factor was off by a long shot. Needless to say, we didn't place in the top ten...

Star of Knoxville Dinner Cruise.

After the Rally, we took a Dinner Cruise up the Tennessee River on the Star of Knoxville paddle wheeler. The boat was packed to capacity with CORSA Conventioneers, but the buffet style dinner was tasty and the service was surprisingly prompt and courteous for such a large crowd. The scenery on the cruise was nice, too, once we got north of the city limits. There are a number of mansions on the riverbanks,

with boat houses and impressive landscaping. Zillionaire country!

The Star of Knoxville is an authentic old-fashioned paddle wheeler and it was originally powered by steam. But now it runs on diesel power. The diesel engine powers hydraulic pumps, which in turn, power big hydraulic motors located on the axles of the paddle wheel. The paddle wheel remains the sole source of propulsion. There are no screw propellers on the Star of Knoxville. I don't know why, but such things are important to me!

Autocross.

The next day, Friday, Karen went sight-seeing in Knoxville while I ran in the Autocross. It was held in a big city park. The circuit had an uphill-downhill elevation change and was well-identified with plenty of marker cones. I usually don't like autocrossing because the courses are too tight and it's difficult to figure out exactly where the course goes. From the drivers seat, it just looks like a sea of traffic cones. But this one was easy to decipher and pretty fast to boot!

Awards Banquet.

The Social Hour and Awards Banquet came next. I was hoping we would receive another award for the LVCC newsletter or perhaps our website, but it was not to be. But I got trophies for the Economy Run and Autocross, so I didn't come home empty-handed.

In the Autocross, I scored second place in my class. And in the Economy Run, I scored fourth place in my class with 31.681 miles per gallon. In comparison, the first-place driver got 53 miles per gallon! The crowd at the Banquet

(Continued on page 4)

KNOXVILLE CORSA CONVENTION

A sample of scenes



Corvairs at the Concours d' Elegance.



Lining up for the Economy Run across from the hotel.



Going up into the Great Smoky Mountains.



Karen Lacki touring the City of Knoxville.



Corvairs lined up or the Autocross.



Al Lacki's Corvair getting some rest at the Car Display.

reacted with a combination of cheers and guffaws at the incredulous performance! Stiff competition indeed.

Corvair Car Display.

Saturday was the last day of the Convention. Only one activity was scheduled for that day - the Car Display. The weather forecast called for rain, but the organizers were ready. They changed the venue from the hotel lawn to the Knoxville Civic Coliseum parking garage located just across the highway so everybody could stay dry. Although some people left Knoxville to go home that morning, others including Karen and me stayed for the Car Display. And so, I got to show off LeHeap.

Applause!

This was my fourth CORSA Convention and I had more fun at this one than at any other. I can't speak for the Concours because my Corvair isn't concours material, but each of the other events - the Economy Run, Rally, Autocross, Car Display and Banquet - were properly organized and orderly.

I also have to put in a plug for the Knoxville Area Corvair Club (KACC). That's the chapter of CORSA that organized this convention. They chose the Marriott of Knoxville as the host hotel. It's located in the city, but it is so easy to access and the amount of available parking was ample to say the least.

Somehow, KACC also snagged city officials into lending one of the multi-level Knoxville Civic Coliseum parking garages just across the highway. This garage served as the venue for outdoor vendors and trailer rigs as well as overflow parking for the hotel. The garage is connected to the hotel by a covered causeway which made it easy to walk between the two. And this was in addition to the hotel's own parking garage.

The hotel was big, neat and well-maintained, with a nice restaurant and bar. And the rooms were clean and modern with comfy beds. I slept better there than in my own bed!

ANOTHER PORSCHE HORIZONTAL FAN KIT

While many Corvair racers pine for a vertical engine cooling fan kit, it seems some Porsche guys can't live without a horizontal cooling fan!

The cooling fan on a four-cylinder Porsche 914 engine is mounted directly to the crankshaft. No fan belt is necessary to drive the cooling fan on a Porsche 914. But a couple of years ago, a racing equipment manufacturer named Tangerine Racing began to offer a horizontal fan kit for these engines.

The Tangerine kit's horizontal fan was mounted on top of the crankcase and was driven by a twisted belt just like a Corvair. The manufacturer claimed that the horizontal fan offered superior cooling in comparison to the crankshaft-mounted fan that came from the factory. Some commenters were skeptical, recalling all the old horror stories about Corvairs flipping fan belts.

Well, now we have a new twist on horizontal fans. A company named Bailey North America is offering a horizontal cooling fan kit for six-cylinder Porsche engines. But this time, there is no twisted belt involved in the design. Instead, the fan is driven by a shaft-and-gear arrangement that enables the use of a conventional single-plane fan belt.

Now, six-cylinder Porsche engines are equipped with vertical cooling fans from the factory, and they don't have any particular cooling problems. So why would anyone want to replace the original equipment vertical fan with a horizontal one?

It just so happens that Bailey makes high-zoot Porsche 917 replicas. And Porsche 917s had horizontal fans. You wouldn't want a vertical cooling fan on your Porsche 917, would you?

Here is what the Bailey website says about its product:

This is a 'serious' top mounted cooling fan. After many hours of R&D, the Bailey team has designed this outstanding 917 look alike top cooling fan. This is a true work of art. This fan functions as good as the current 911 fan, if not better. It has all the necessary parts to cool the engine and run at high RPM's, such as bevel gear drive main shafts, bearings, poly-V belt and pulleys, billet gear box housings, anti-backlash coupling, fan and shroud available in carbon fiber, Kevlar, or fiber glass. These highest quality parts allow the fan to spin up to 10, 500 RPM. This fan will give your 917 or 935 IMSA the major WOW factor.

Now, if you were a Corvair racer, you might contemplate adapting a Bailey horizontal fan kit to a your 3.1 liter 300 horsepower Corvair engine. No more worries about throwing fan belts during those 7,000 RPM downshifts!

But there is only one problem. The Bailey kit costs-hold onto your hat-\$13,500! (Shipping included).

JUNE LVCC MEETING NOTES

Six members. Dennis Stamm, Fred Scherzer, Jerry Moyer, Larry Lewis, Scott Oberholtzer and Dick Weidner attended our June meeting. Dick read the minutes of our May meeting and gave the financial report.

Balance from May \$1,269.13

RECEIPTS

6/15 No Receipts	\$.00
TOTAL	\$.00

EXPENDITURES

6/15 Newsletter	\$ 27.74
TOTAL	\$ 27.74

BALANCE \$ 1,241.39

The only club business conducted was a discussion on whether to hold a July 22 meeting due to the closeness of the date of our show at the Das Awscht Fescht. The decision of the
(Continued on page 6)



Porsche 911 horizontal cooling fan kit by Bailey.

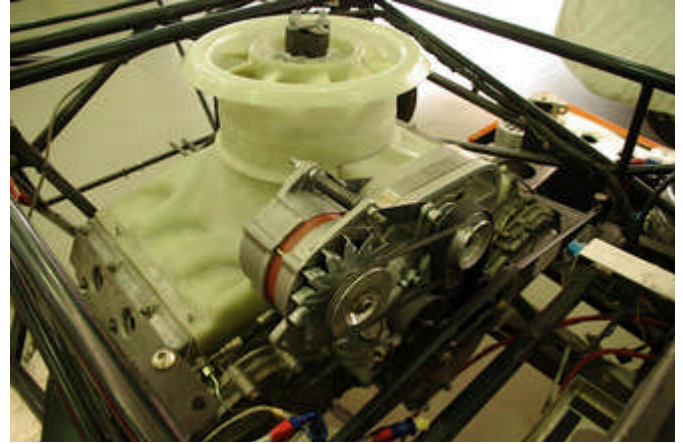

The Bailey fan kit, installed.

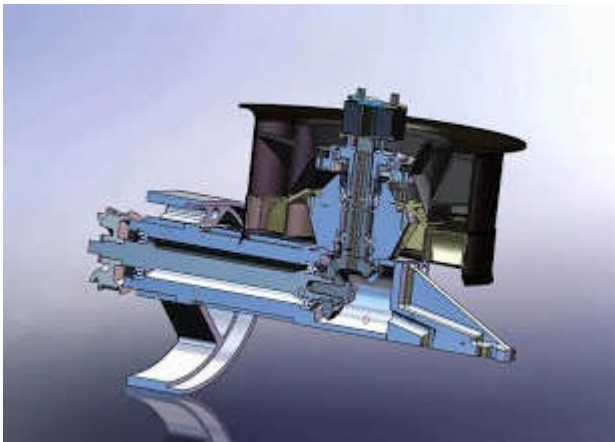

Jack-drive arrangement for the Bailey kit.



Your Porsche 917 replica needs a horizontal fan!



Here is the Tangerine Racing Products kit for four-cylinder Porsche 914s.

HORIZONTAL FAN CONVERSION KITS FOR PORSCHE!

We covered the Tangerine Racing Products kit in the July 2011 issue of The Fifth Wheel. It made use of the Corvair-style fan belt arrangement. Here, we show photos of the Bailey kit for Porsche 911 engines. Gear-driven. \$13,500. Ouch!

membership was to hold the July meeting.

Scott Oberholtzer described a lifter problem he was having with his Corvair. Scott removed and replaced the problem lifter and brought the problem lifter to the meeting. It was explained that lifters can pick dirt and carbon deposits. Lifters can also be disassembled cleaned and returned to service.

Using his computer and projector, Dick Weidner presented photo CDs of the 2008 trip to the DACC Show in Plymouth MI. He and LVCC Member Jerry Moyer attended this event. The presentation also included pictures from the GM Heritage Museum and the Corvair Museum in Ypsilanti MI. Dick also had some GM Corvair promotional videos.

CAN THIS CORVAIR BE SAVED?

A long-running Ladies' Home Journal column that started in 1953, called "Can This Marriage Be Saved?," features real-life couples and the juicy details of their marital issues.

The columns were split into three parts: a wife's perspective, her husband's take and then final judgment by a counselor

from the American Institute of Family Relations. AIFR was a successful, but now defunct, center founded in the 1930s by "Dr." Popenoe. He wasn't actually a doctor or a psychologist but a eugenicist with an honorary degree. Very often, Popenoe's counselors found a way to pin problems on the wives, calling them "childish," "juvenile," "emotionally immature" and "frigid," for example.

We've come a long way baby. But today, a similar question arises on the Corvair message boards: Can This Corvair Be Saved?!!

Often, the message board topic begins with a threat to send some poor rusty Corvair "to the crusher!" And then, the fun begins. Commenters post replies full of outrage and anger. How can one be so insensitive as to make such a vile threat? Every Corvair must be saved!

This, of course, is poppycock. There are plenty of Corvairs that should be broken down for parts and scrapped rather than restored. Economically, it never makes sense to restore a Corvair that has, say, a tree growing through the roof.

The question then becomes, what is the point of no return, when it is better to scrap than save? There is no hard and fast answer to this question. It is al-

most always cheaper to buy a fully-restored Corvair from someone else rather than restore an old rust bucket. For a collector who wants a show quality Corvair, it's hard to justify the cost of restoration. Yet so many Corvair owners do it. It's a labor of love.

How about the Average Joe, who simply wants to have an old Corvair to knock around in? The hobbyist who isn't interested in winning trophies at the Concours d' Elegance?

Average Joe needs to shop carefully to avoid purchasing a money pit. And the ultimate money pit is a Corvair that is structurally unsound.

What do we mean by that? We're talking about Corvairs that are so badly rotted that they are in danger of breaking apart on the highway. Cars that won't hold a wheel alignment, cars with front suspension cross-members that are in danger of collapse, cars that twist and flex over every bump.

Can such maladies be fixed? Yes, but unless you are a skilled welder, the cost will be dear. If you are in the market for a restoration candidate, or even just a car to knock around in, it may be better to just walk on by.



Holes in the floor are quite common in un-restored Corvairs. They can be fixed using steel patch panels. If the rust extends up into the wheel houses, then the repair job becomes much more difficult.

When evaluating an old car, it's always a good idea to peel back the floor covering to examine the condition of the floor pans. Or better yet, have the owner put the car up on a lift so that you can examine the underside.

Check out the floor in the trunk, too!

Late series Corvairs, from 1965 to 1969, often suffer from windshield channel rot. In and of itself, this is not a structural problem, but it can be a tale-tell sign of deeper corrosion. It may extend to the door hinge mounting points.

And old trick: Make sure you can move the car up and down by lifting on the door while it is all the way open. Start easy. You don't want to end up with only the door in your grasp. The seller may not like that much!

On this particular Corvair, the windshield has stress cracks and has started to delaminate, too.

Corvair convertibles have reinforced rocker panels to stiffen up the body. This convertible is rusted at the rocker area at the rear of the door. The corrosion goes straight through. This is a stress point in the unit body. The channel between the inner and outer seams appears to have been recently painted, possibly with POR-15 paint. What does that say about the condition of the rocker panel reinforcement beam inside?



LVCC Classified Ads!

FOR SALE: 1965 Corvair 500 Coupe. 110 hp engine. Powerglide. 45,156 original miles. Good solid car; no dents, no rust. 14 inch Rally wheels, Pioneer stereo with CD player, Legacy 400 watt speakers. \$5,500 or best offer. Will deliver in 75 mile radius of Mohrsville, PA. Being offered by LVCC President Dennis Stamm. Call (610) 926-4723 (home) or (484) 336-3466 (cell) or email dmstamm@comcast.net



FOR SALE: 1962 Corvair 700 Station Wagon. 102 horsepower 4 speed, 23,000 miles, all original, unrestored but refurbished in 2000. Certified by the AACA for "Historical Preservation of Original Features (HPOF)". Engine and trans resealed, door edge guards, all new metal brake lines, new fawn carpeting and engine cover. Many additional features. Runs and drives like new, does not smoke or use oil. Quick shifter. A real turn key and drive vehicle. \$13,900 or best offer. Call Fred Scherzer at 484-948-5142. Email: jukeboxman@comcast.net



FOR SALE: I have a 1962 4 door automatic Corvair that last ran in 1995. This Corvair needs a lot of work. Would any of your members be interested? I don't have time to do the work. It would be a good project or parts car. Please let me know. George Myers. Phone (610) 216-0510. Email: geomyers11@gmail.com

FOR SALE: Set of 4 1964-66 13 inch Chevrolet factory wire wheel covers for Corvair and Chevy II. Minor curb rash on one, but otherwise in very nice condition. Photos available on request. \$100 for the full set. Will deliver within 25 miles of Reading, PA. Allan Lacki. Phone: (610) 927-1583. Email redbat01@verizon.net

FOR SALE: 1966 Chevrolet Corvair Monza Sport Coupe. 110/PG. Very original car. Nice patina (mostly original paint). 34K original miles. Window sticker and POP. Second owner. Very solid car. Artesian turquoise with black interior. Unusual AM radio/rear seat speaker. Car was a dealer demo for Ray Mills Chevrolet in Doylestown, PA. No leaks and clean heat. Only mods from original are battery, halogen headlights, seat track extenders and Ignitor II ignition. Runs and drives very well. Recent brake overhaul. Has NOS nosebar, 3 bar "street" wire wheel covers, NOS tail light lenses, repro wheel well moldings. Also comes with original wheel covers with NOS centers installed. 26 MPG average on its last AACA national tour. Car is located in Phillipsburg, New Jersey. Price of \$8,500.00 is negotiable; but the car must go to a good home. Contact Ron Peles by phone at 908-479-1777 or by email at . ronaldpeleslaw@gmail.com



Three Big Pages of Local Events!

Thursday, July 16, 2015 :::: Dewey Fire Company Cruise in Hellertown

Location: Morris J. Dimmick Park, 570 Durham Street, Hellertown, PA 18055. Time: 6:00 PM to 10:00 PM. This year will mark the 100th year that Dewey Fire Co. has hosted a community carnival. We would like to invite you to help us celebrate and attend our Centennial Carnival Cruise. Bring and display your antique, street rod, tuner pick up truck, classic any type of vehicle welcome. Price: Free. <https://www.facebook.com/events/1395723644073694/>

Saturday, July 18, 2015 :::: Wheels of Time Cruise Night at Macungie

Location: Macungie Memorial Park, 50 S Poplar Street, Macungie, PA 18062. Begins: 5 PM. Price: \$1 per car. This is for repair and reconstruction of **Sunday, July 12, 2015 :::: Road Angels of Doylestown Street Rod Club Show & Shine**

Location: Moravian Tile Works Grounds, Route 313 & Cold Spring Creamery Road, Doylestown, PA 18901. Time: 9:00 AM to 3:30 PM. Price: Pre-registered \$14. Day of Show \$20. Event description: All street rods, customs, muscle cars, trucks, classics & antiques 30 years old or older **Saturday July 11, 2015 :::: Cruise Night at Harleysville Wal-Mart**

Location: Wal-Mart, 651 Main St, Harleysville, PA 19438. Time: 2 PM to 8 PM. Members of the Philadelphia Corvair Association will be showing their cars at this event.

Sunday, July 12, 2015 ::::: New Holland Antique Car, Gas Engine & Tractor Show

Location: New Holland Community Park. Time: 9 AM to 3:30 PM. Judged show. Includes Corvair class. Judged show. You must pre-register for this event by are welcome. Door prizes and cash prizes will be awarded. Contact info: Phone: (215) 622-5449. Registration form: <http://roadangelsdoylestown.com/RARodReg2015.pdf>

Sunday, July 12, 2015 :::: Leave Cystic Fibrosis in Our Dust Car Show

Location: Bethlehem Steel Stacks, 101 Founders Way, Bethlehem, PA 18018. Time: 11 AM to 4 PM. Prices: Pre-register before June 1 for \$15. Day of show: \$20. Event description: All cars the children's play area. <http://www.wheelsovertime.org/local-cruises-events/>

Saturday, July 18, 2015 :::: 1st Annual Pep Boys Coffee & Cars Show in Quakertown

Location: Pep Boys, 222 S West End Blvd, Quakertown, PA 18951. Time: 8 AM to Noon. Rain date: July 25. Price: \$15 per car. Door prizes, 50/50, trophies. For more info, call Jim Hunsberger at (215) 313-7033 or Chris Mills at (267) 745-3626.

Saturday, July 18, 2015 :::: Cruise Night at Heisler's in Tamaqua

Location: Heisler Cloverleaf Dairy Bar, 743 Catawissa Road, Tamaqua, PA 18253. Time: 5 PM to 8 PM. All vehicles and motorcycles welcome. Dash plaques, 50/50, music, miniature golf, food, and ice cream. Host: Tamaqua Street Machines Association. Email address: tamaquastreetmachine@gmail.com

Sunday, July 19, 2015 :::: Cruise Night at Country Square Shopping Center, Quakertown

Location: Country Square Shopping Center, 240 South West End Blvd. (Rt. 309), Quakertown, PA. Time: 4 PM to 7 PM. No rain date. All makes, models, and years welcome. 50/50. Donations accepted for St. Isidore Food Pantry (Quakertown). Contact info: Email Rich at rjenders@verizon.net or call Roger at (215) 896-4351.

Sunday, July 19, 2015 :::: Cruise Big Woody's in Bethlehem

Location: Big Woody's Pizza & Sports Bar, 2625 Easton Avenue, Bethlehem, PA. Time: 5:30 PM to 8:30 PM. Door Prizes; 50/50. Benefits "Camelot House for Children" & Wounded Warriors. Host: Blue Mountain Classics. Contact info: Call Donna at (610) 625-0851.

Sunday, July, 19 2015 :::: Crazy for Cars Show

Location: Memorytown USA, Grange Road, Mount Pocono, PA 18344. Time: 10:00 AM to 3:30 PM. Price: \$10 per car. All makes, models, years, welcome. Muscle, imports, hot rods, antiques motorcycles & trucks. music, raffles, trophies. Hot Food and Cold Drinks available Contact info: Phone: (570) 460-2918. Email: jantak75@aol.com

(Continued on page 10)

Three Big Pages of Local Events!

(Continued from page 9)

Saturday, July 25, 2015 :::: Dairy Queen Car Show for the Humane Society

Location: Dairy Queen, 820 Kenhorst Plaza, Kenhorst, PA 19607. Time: 4 PM to 8 PM. Rain or shine. Price: \$10. Open to all cars, trucks & motorcycles. DJ, food, silent auction, 50/50, dash plaques and trophies. Contact info: Email Teresa Glahn atteresa@bcmcci.com Website: www.bcmcci.com

Saturday, July 25, 2015 :::: Eastwood Summer Classic in Pottstown

Location: Eastwood Retail Store, 263 Shoemaker Road, Pottstown, PA 19464. Time: 8:30 AM to 3 PM. Price: \$5 per car. Rain date: Sunday, July 26. Show includes huge in-store sales - Live demos with Eastwood experts - Music, food, t-shirts, raffle, swap meet, etc. Contact: Nick Capinski by phone at (800) 343-9353 or by e-mail at ncapinski@eastwood.com <http://www.eastwood.com/custserv-store>

Saturday, July 25, 2015 :::: Kutztown Kruizz in Kutztown

Location: Main Street, Kutztown, Pennsylvania 19530. Prices: Pre-register for \$10 at <https://squareup.com/market/kutztown-community-partnership>. Day of event price is \$15. Schedule: 1:30 Registration begins at Kutztown High School. 2:30 Main Street Staging begins. 3:00-6:00 Car display & activities on Main Street. 6:00 Cars are invited to roll down to Park for concert/movie. 7:00 Concert begins in band shell at the Kutztown Park. 9:00 Movie on the lawn below the Keith Haring Statue. The movie is "American Graffiti". Concert includes three bands including The Fabulous Grease Band. <http://www.keepinitkutztown.com/#fc1>

July 31 through August 2, 2015 :::: Das Awkscht Fescht in Macungie PA

Location: Macungie Memorial Park, 50 N. Poplar Street, Macungie, PA 18062. Time: 7:30 AM to 4:30 PM. Event description: Cars, flea market, arts and crafts, music, and entertainment for the entire family at beautiful Macungie Memorial Park near Allentown. On Sunday LVCC participates in Club Day featuring 34 marque car clubs.. You must pre-register before July 1 to enter the show! Registration forms and pricing are available at <http://www.awkscht.com/>

Friday, August, 7 2015 :::: Hatboro Cruisers First Friday Cruise Night

Location: Speed Raceway, 200 Blair Mill Rd., Hatboro, PA 19044. Time: 5:00 PM to 8:30 PM. Price: free. Please feel free to come out and cruise the town of Hatboro again meet us up at the Speed Raceway and see the beautiful cars, bikes and trucks on display. Lots of fun for all. Contact info: Email: alfsturn@comcast.net

Saturday, August 8, 2015 :::: All Corvair Show in New Castle, Delaware

Location: New Castle Moose Lodge, 621 S. Dupont Hwy, New Castle, DE 19720. Time: 9:00 AM to 3:30 PM. Price: Price: Not listed. Lunch provided with registration. Hosted by First State Corvair Club. Contact by phone: (302) 377-5268. Email: slinkslot@verizon.net

Monday, August 10, 2015 :::: High Performance Driving with Northeast Corvair Council (NECC)

Location: New Jersey Motorsports Park, 8000 Dividing Creek Rd, Millville, NJ 08332. High performance driving event with group practice sessions, open track, and timed laps. Lehigh Valley Corvair Club is a member of NECC. Complete details at www.neccmotorsports.com.

Saturday, August 15, 2015 :::: The Great Phillipsburg Auto Show

The Show Chairman is our very own Ron Peles! Location: St. Philip & St. James School, Roseberry Street, Phillipsburg, NJ. Time: 8 AM to 3 PM. Rain date: 08/16/2015. Show cars will be on the grass. We will have a flea market and food. Ron has declared this show WILL have a Corvair class! Contact: Ron Peles (908) 479-1218 rpeles@embarqmail.com Additional info: www.kofccouncil474.com

Saturday, August 15, 2015 :::: Wheels of Time Cruise Night at Macungie

Location: Macungie Memorial Park, 50 S Poplar Street, Macungie, PA 18062. Begins: 5 PM. Price: \$1 per car. This is for repair and reconstruction of the children's play area. <http://www.wheelsoftime.org/local-cruises-events/>

(Continued on page 11)

Three Big Pages of Local Events!

(Continued from page 10)

Sunday, August 16, 2015 :::: 16th Annual Sticks Reunion Car Show

Location: Old Mountain View Drag Strip, East Mountain Road (Route 512), Wind Gap, PA 18091. Time: 10:00 AM to 3:00 PM. Pre-registration price before August 10: \$7. Day of show price: \$10. Muscle cars, street rods, vintage drag cars, antiques, classics, 4x4s, motorcycles. DJ, food, trophies, door prizes. Contact info: Call Pro Zito at (610) 588-0521 or Wayne Bisher at (610) 703-4889. Email zitosspeedshop@rcn.com Flyer: http://www.hi-winderscarclub.org/sticks/16th_annual_sticks_flyer.pdf

Saturday, August 22, 2015 :::: Branches, Brawn, and Beauty Car Show

Location: Souderton Mennonite Homes, 207 W Summit Street, Souderton, PA 18964. Registration begins: 7:30 AM. Show from 9:00 AM to 3:00 PM. Pre-registration price: \$10 up to August 21. Day of show price: \$15. This is the 40th year for this car show, auction, and chicken BBQ used to help support the residents of this retirement community who can no longer afford to pay for their care. All cars must have a fire extinguisher on board. No alcohol, no motorcycles. Contact info: Call Becky Whipple at (215) 368-4438 ext 44110. www.livingbranches.org

Saturday, September 5, 2015 :::: 50th Annual Duryea Day Car & Truck Show

Location: Boyertown Community Park, 417 Madison Street, Boyertown, PA 19512. Registration from 8:00 AM to Noon, Show from 8:00 AM to 4:00 PM. Pre-registration price to August 29: \$10. Day of show price: \$12. Contact info: (610) 367-2090. www.boyertownmuseum.org

Saturday, September 12, 2015 :::: Corvair Days in Hershey PA

Location: AACA Museum, 161 Museum Drive, Hershey, PA 17033. Time: 8 AM to 4 PM. Hosted by Central Pennsylvania Corvair Club. Event description: The day will begin with a road rally, scavenger hunt in the museum, and people's choice car show. We will raffle off \$100 gift, plus door prizes, and 50/50 drawing. Registration includes admission to the museum and a food voucher. Contact by phone: (717) 991-7341 Email: earlzgames@comcast.net

DAS AWKSCHT FESCHT REMINDER!

Join LVCC on Sunday, August 2, for Club Day at Das Awkscht Fescht. If you want to show your Corvair but didn't register, you're out of luck. Show car registration closed on July 1st!

But that doesn't mean you're shut out of this event. You can walk in as a spectator and join us beneath the LVCC EZ-Up, where we'll have a brief meeting and be awarding door prizes in the afternoon.

And in addition to the forty or so Corvairs on display, there will be literally hundreds of other interesting cars to see at the show, not to mention the huge vendor area.

You can spend the better part of your day at Das Awkscht Fescht on Sunday, even if you don't show your Corvair.

Mail Dues to:

Lehigh Valley Corvair Club
c/o Richard Weidner
2304 Main Street
Northampton, PA 18067

LVCC Club Officers:

President: Dennis Stamm Phone: (610) 926-4723 Email: dmstamm@comcast.net
Vice Pres: Fred Scherzer Phone: (215) 234-4458 Email: jukeboxman@comcast.net
Secr-Treasurer: Richard Weidner. Phone: (610) 502-1414 Email: rcwvair@rcn.com
Newsletter Editor: Allan Lacki. Phone: (610) 927-1583 Email: redbat01@verizon.net



Warren Council #474 Presents:

The Great Phillipsburg Auto Show

Saturday August 15th, 2015

8:00 am - 3:00 pm

(Rain date August 16th, 2015)

**INCLUDES
CORVAIR
CLASS**

On the Grounds of St. Philip & St. James School
Roseberry Street, Phillipsburg, New Jersey

All Proceeds Benefit GRANDMA'S HOUSE

*A home for women homeless and pregnant
A Project of Life Choices, a 501(c)(3)
Charitable Organization
(Registration not tax-deductible)*



REGISTRATION INFORMATION CONTACT:

Ron Peles Show Chairman (908) 479-1218
ronaldpeleslaw@gmail.com

WEB SITE: www.kofccouncil474.com for additional information

SHOW FEATURES

*Express Day of Show Registration, Goodie Bags, Door Prizes, Awards
Family Entertainment, Delicious Food*

FAMILY FUN FOR ALL

- All Preregistration ends August 1, 2015
- SHOW CARS Pre-registration \$10, Day of Show \$15
- CAR CORRAL Pre-registration \$10, Day of Show \$15
- FLEA MARKET Pre-registration \$10, Day of Show \$15 (Must Exhibit NJ Sales Tax No.)
- SPECTATORS Day of Show: \$5 Per Car, includes parking, \$2 per person on foot

Flea Market Spaces are 10' x 15, (no reserved spots)



Here is a flyer for the car show that is being arranged by LVCC Member Ron Peles. Phillipsburg, NJ is a quick ride from the Lehigh Valley. It includes a Corvair Class, so come on out and show your Corvair!



Clark's Corvair Parts®

400 Mohawk Trail, Shelburne Falls, MA 01370
(413)625-9776 www.corvair.com



Our 42nd Year! Get the 2013-2018 Catalog

If you did not get our latest catalog in 2013 or 2014, you can get one free on your first \$50 order during 2015. (Additional catalogs \$3 with an order)

Over 100 new repro parts in the past 3 years.