



# *the fifth wheel*

Winner of the 2014 CORSA Tony Fiore Newsletter Competition

SEPTEMBER 2017

[HTTP://WWW.CORVAIR.ORG/CHAPTERS/LVCC](http://www.corvair.org/chapters/lvcc)

ESTABLISHED 1976

## **Inside this issue**

Next LVCC Meeting:  
Wednesday 9/27/2017 1

Phil Levering Scores  
at CORSA Convention! 2

LVCC Welcomes  
3 New Members 2

Robesonia Car Show  
Report 2

LVCC Meeting Notes  
from July 2

Photo Gallery: Compact  
Cars at Robesonia 3

Singh Grooves for  
Your Cylinder Heads 4

After the Storm. How to  
Save Your Corvair 4

Corvair Cooking Corner  
By Mary Ann Stamm 6

Chrysler A57 Multibank  
Tank Engine 6

Cruise Night Schedule:  
Where? 7

LVCC Classified  
Ads 8

Local Car Shows &  
Other Events 9

LVCC Officer  
Contact Information 10



## ***Next Meeting: Wednesday 09/27/2017***

Time 7:30 PM. Place: Lehigh and Northampton Transportation Authority Headquarters (LANta), 2nd Floor Meeting Room, 1060 Lehigh Street, Allentown, PA 18103. Latitude : 40.587607 | Longitude : -75.474405. Bring a guest!

Don't get locked out. If you arrive late, the main door of the LANta office building may be locked. This is for security purposes. But the facility is open around the clock, so ask one of the garage employees to direct you to the second floor.



*The Fifth Wheel* is published monthly by Lehigh Valley Corvair Club Inc. (LVCC). We accept articles of interest to Corvair owners for publication. Classified advertising of interest to Corvair owners is available free of charge to all persons. Commercial advertising is also available on a fee basis. For details, email our newsletter editor, Allan Lacki, [redbat01@verizon.net](mailto:redbat01@verizon.net).

## **Phil Levering Scores !**

LVCC's Phil and Joanne Levering, driving their 1965 Corvair Corsa convertible, just missed winning the overall Ed Cole Award at this year's Corvair Society of America Convention by 1.49 points out of 1,080!

In addition, they won the Manual Transmission, Four Carb class in the Economy Run and the Street Stock 4 class in the Autocross.

The Edward N. Cole Memorial Award was established nearly four decades ago (1978) to honor the memory of Edward N. Cole as the father of the Corvair. This award perpetuates his memory by conducting an annual competition of the highest standards in all facets of Corvair activities. The International Corvair Convention is the only opportunity members have to participate in this exciting and rewarding competition

### **Congratulations Phil & Joanne!**

## **New Members!**

LVCC gained three new members in August. They are John Egerton, Chuck Mason and Kyle Regan.

John returns to LVCC after several years having been active in the Blue Mountain Corvair Club and the Northeast Corvair Council in the interim.

Chuck Mason hails from Eagleville, PA and is an avid car enthusiast. In addition to his appreciation of Corvairs, he is, or at least was, a member of the Free Spirit Chapter of the Buick Club of America.

Kyle Regan was a spectator at Das Awkscht Fescht last year and was so impressed with our display of Corvairs that he vowed to get one for himself. He's now the proud owner of a Corvair Corsa.

## **Robesonia Car Show**

by Allan Lacki

On Labor Day, I took my Corvair to the Stewart's Root Beer Car Show in Robesonia. This was billed as the successor to Kauffman's Annual Antique & Custom Cruise-In with which you may be familiar. Kauffman's no longer sponsors the show, so it has moved to Robesonia instead.

381 cars showed up and that was way more than expected. But the Robesonia recreation field was large enough to accommodate all of us. There wasn't much shade but the grassy lawns were very nicely maintained. It sure beats asphalt in the sun!

In addition to five Corvairs, some early '50s compact cars were on display. All of them were highly customized, but it was nice to see them just the same. They included a Nash Rambler wagon, a Willys Aero and a Henry J. The only one missing was a Hudson Jet. I haven't seen one of those in a long, long time!

Of course, there were dozens of Corvettes, Mustangs Camaros and hi-po Mopars at the show. I don't recall seeing any brass-era antiques, which are always interesting, but there were some original un-restored cars, including a '35 Chevrolet Standard business coupe. And speaking of un-restored originals, I was parked next to a super-clean 1963 Corvair Monza sedan owned by John Sterley. John isn't interested in car clubs so I didn't attempt to corral him into LVCC, but he often shows his Corvair and that's a good thing.

Music was provided by Flamin' Dick and the Hot Rods, a 50's and 60's rock-n-roll party band that plays a variety of music from the years of 1955 to 1968 - "The Golden Years of Rock-n-Roll." This band attracts a lot of older groups and they showed up in abundance at Robesonia. The band and the crowd were separated by a side street where rockers danced to the music and, in back of that, the audience was seated in

their portable chairs five rows deep. It was quite a sight.

## **LVCC Meeting Notes**

Our meeting of August 23 was attended by Steve Hurst, Larry Lewis, Allan Lacki, Ed Prescott, Fred Scherzer, Dennis Stamm and Dick Weidner.

Official Reports. Dick read the minutes from our June meeting and the treasury report for July. According to Dick we had \$1,204.82 in our treasury account at the beginning of the month. Expenses amounted to \$62.90 for photocopy, postage and other supplies related to the newsletter. This left a balance of \$1,141.92 at the end of July. Dick pointed out that the end-of-month balance for July does not account for several hundred dollars in dues payments received during August, so the treasury is actually in better shape than reported here. The minutes and treasury report were approved in accordance with parliamentary procedure.

Other Chapter Business. For several years, LVCC has been using an EZ-Up canopy owned by Randy Kohler's sister at Das Awkscht Fescht. A motion was made to have LVCC to purchase an EZ-Up of its own. The motion was seconded and approved.

Larry Lewis agreed to have an acquaintance of his do a presentation for us at our March 2018 meeting. Larry's friend is an expert on historic license plates going back to the early days of motoring in Pennsylvania.

Allan Lacki agreed to file LVCC's IRS tax return for the year ending July 31, 2017. (This has been completed).

Member News. Steve Hurst discussed his progress in building a high performance engine for his early Corvair. Among other things, it will be equipped with modified 140 hp cylinder heads. In addition to porting and polishing the intake and exhaust runners, Steve has opted to cut "Singh Grooves" in the

# Compact Cars at Robesonia Car Show!



Two of the five Corvairs at the show



Early '50s Compacts. A Willys Aero!



Early '50s Compacts. A Henry J!



Early '50s Compacts. A Nash Rambler wagon!



John Sterley's flying wing roof. Unrestored 'Vair!



Flamin' Dick & the Hot Rods had people dancing!!

combustion areas of the heads. The Singh Groove theory is explained in another article of this newsletter.

Jerry Moyer asked everybody about the kind of engine oil they are using. Steve Hurst and Al Lacki said they are using Brad Penn oil. Steve added that, for new engines, be sure to use petroleum-based oil until the piston rings seat-in. Dick Weidner said he is using Mobil high-mileage oil with good results. All agreed that, unless the engine has roller rockers, the oil of choice needs sufficient ZDDP (zinc) content to protect camshaft and tappet surfaces.

Ed Prescott continues to work on the rear suspension of his Corvair Corsa. A friend of his brother's pressed new bushings into one of the lower strut rods, but the rubber part of the bushing is offset to one side. Fred Scherzer and Dennis Stamm gave advice on how this can be corrected. Dennis offered to do it for Ed. Ed took down Dennis' phone number.

Pass It Around. Dick Weidner passed around a number of additional items from his amazing collection of Corvair memorabilia. They included several booklets published by the Chevrolet Motor Division, including testimonials from Corvair owners, servicing windshield wiper motors and linkages, instructions for adjusting curved glass windows in late Corvairs, and general procedures for overhauling Corvair mechanicals.

## ***Singh Grooves***

The theory: An engineer named Somender Singh has been awarded an US Patent for his discovery of how to gain more engine power and economy by utilizing a small groove cut into the squish area(s) of internal combustion engine cylinder heads. The groove(s) allows gasses to expand and compress with an effect that has, in certain instances, improved fuel efficiency, lowered operating temperature, improved torque and max power as well as lowering idle speed.

The groove has beneficial effects on the compression stroke as well as the power stroke. On the compression stroke, the groove channels the last bit of air / fuel mixture towards the combustion area, maintaining swirl until the spark provides ignition. On the power stroke, the groove provides a channel for hot gasses to jet towards the cylinder wall and ignite comparatively more mixture in the squish area. It also appears that the groove can destroy standing vortices in the squish areas as well. That's a good thing.

Does it work? Some people say the groove theory pans out. Others say they work for a while until the grooves become carbonized, at which point, the performance improvement diminishes .

LVCC member Steve Hurst is rebuilding an engine for his Corvair and has opted to cut Singh Grooves in the cylinder heads. Steve is an accomplished engine builder, so he is comfortable in trying new things. He promised to keep us apprised of the results!

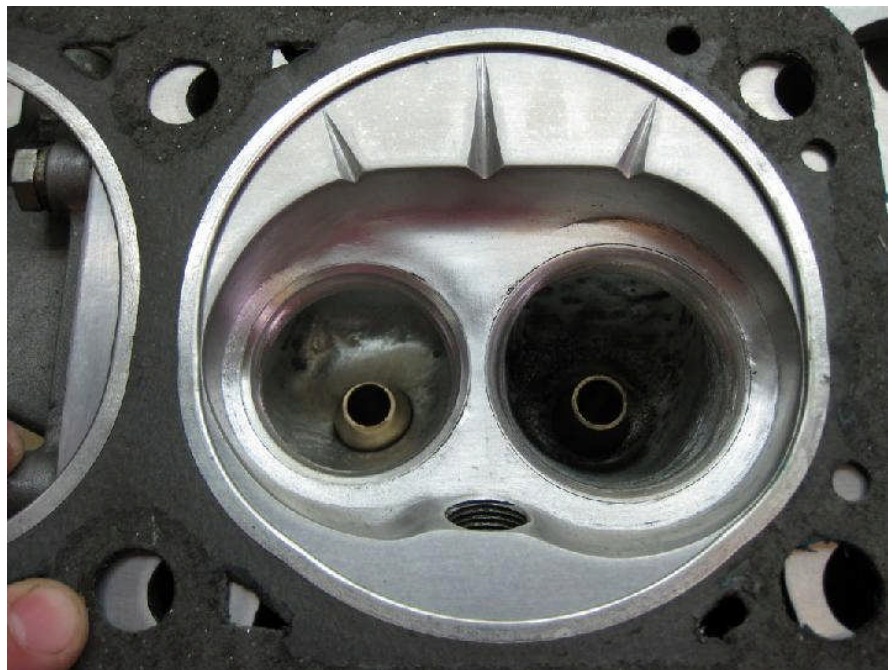

Although not a Corvair cylinder head, here is a photo showing a head that has been modified with Singh Grooves.

## ***After the Storm***

The summer of 2017 has been wet and wild in many sections of the country and the news reports are filled with stories of widespread flooding. With everything else going on, a water-logged Corvair is probably low on the list of priorities, or at least it should be. But if your Corvair has been damaged by flood waters, you'll eventually need to assess what can be done to save it.

Your repair options depend on the extent of the flooding, water type, depth and duration of submersion. Naturally, a car that's been totally submerged will need a lot more attention than one that was in a few inches of standing water. Salt water is more corrosive than fresh water; rust will set in quickly. And water is likely to creep past seals and gaskets when a car has been sitting for days or weeks, rather than a few hours.

Here are some tips to consider, depending on the how badly your Corvair has been flooded. Although this article is written for Corvair owners, the tips apply to other makes and models as well.



We couldn't bear to show you a picture of a flood-damaged Corvair, so here's a Pontiac instead!

1. Act quickly. Get the car out of water and up to high ground as soon as possible. If the water line went above the carburetors or exhaust manifolds, don't attempt to crank the engine. If water has entered the cylinders, the engine will be hydro-locked and any attempt to start it may destroy the pistons, connecting rods, etc. Get the car towed instead. Put the transmission in neutral before moving it.
2. If you suspect water in the cylinders, remove the spark plugs and turn the engine over by hand to force water out of the cylinders. Blowing compressed air into the spark plug holes and intake also helps.
3. Even if the cylinders are not hydro-locked, the oil in the crankcase may be contaminated. Check the oil dipstick. If there are water droplets anywhere on the stick, do not attempt to start the engine. Oil floats on water, making it useless as a lubricant. Don't just drain the oil. Pull the oil pan. That will show you whether there is water in it, how high, and how serious. If you try to run the engine with contaminated oil, it will quickly turn into "mayonnaise". That will clog the pump and the bearings will run dry. After dropping the pan, clean and reinstall it. Then fill the crankcase with fresh oil, and replace the oil filter.
4. You're not done yet. Mud and other debris may have floated into your engine compartment and become lodged inside your Corvair engine's cooling shrouds. At a minimum, remove the oil cooler cover plate and check the cooler. It may be plugged with muck. And if it is, you'll need to remove the top and bottom engine shrouds, too, to clean the cooling fins on the heads and cylinder barrels. Ironically, water may come in handy for this; consider using a pressure washer.
5. Beware. Muddy water can infiltrate its way past seals in a few hours. Automatic transmission discs and bands tend to delaminate in water. Manual transmission synchronizers can be ruined by lack of lubrication, and a soaked clutch may rust to the flywheel. If your Corvair has a manual transmission, the diff case cover has a breather cap on top where water can infiltrate throughout the transaxle assembly.
6. Don't forget wheel bearings. If they were underwater, they will need to be cleaned and repacked.
7. Bleed the brakes. Water-logged brake fluid can vaporize leading to a loss of braking power. Flush the brake system. Brake shoes may spread rust to drums, but moving the car may free them.
8. Check the fuel tank. Siphon some fuel into a container and look for water. If you find any, it's probably best to drop the tank and get it cleaned professionally. Blow out the fuel line, and you may need to get water out of the carburetor float bowls as well.
9. Clean the interior. Use a wet/dry vacuum and cloth towels. Consider removing carpets, insulation and seat cushions. Remove drain plates in the floor pan. Park the car outside on a sunny day, doors and windows open, and lay everything out in the sun. Don't forget the trunk.
10. Clean electrical connectors. Disconnect them, dry them with a hair dryer, and reconnect them. Corvair owners are lucky in this regard. Electrical systems on modern cars are extremely complex. These systems rely on a lot of low-voltage signals from sensors in the engine management system and ABS. These are extremely sensitive to corrosion on connectors and problems can crop up for years.



If you try to run the engine with contaminated oil, it will quickly turn into "mayonnaise".

## ***Corvair Cooking Corner!***

### ***By Mary Ann Stamm***

*Here's a great recipe for colorful Zucchini Bread from Mary Ann!*

#### ***Ingredients:***

*3 eggs, beaten  
1 cup brown sugar  
1 cup white sugar  
1 cup cooking oil  
2 cups coarsely grated zucchini  
1/2 cup applesauce  
2 teaspoons vanilla  
2 teaspoons cinnamon  
3 cups flour  
1 teaspoon baking soda  
1 teaspoon salt  
1 teaspoon baking powder  
3/4 cup chopped nuts (optional)  
1 cup raisins (optional)*

#### ***Instructions:***

*Cream together : sugars, eggs and oil. Add other ingredients. Grease and flour 2 loaf pans. Bake 1 hour at 325 degrees F. Cool in pans for 10 minutes. Remove and cool. You can also make 1/2 of this recipe.*



#### Sources for "After the Storm":

- Corvair Center Forum. "Water Flooded Corvair". a post by Richard Widman.
- State Farm Insurance Company. "Vehicle Floor Damage Checklist". <https://www.statefarm.com/simple-insights/auto-and-vehicles/what-to-do-if-your-car-has-flood-damage>
- National Automotive Parts Association. "Car Flood Damage Repair". <http://knowhow.napaonline.com/car-flood-damage-repair-is-it-possible/>
- Popular Mechanics. "Drying Out Your Flooded Car", by Mike Allen. <http://www.popularmechanics.com/cars/how-to/a70/1272386/>

### ***Chrysler A57 Multibank Engine***

Our meeting discussions often wander off into obscure topics involving industrial technology and so it was not surprising when Dick Weidner began talking about a wacky tank engine manufactured by Chrysler for World War II. Dick described it as a 30 (!) cylinder engine comprised of five six cylinder gas-line engines sharing a common crank case.

Steve Hurst was intrigued by Dick's description and so, the day after our August meeting, he did some research on the internet. And sure enough, Dick proved to be correct. Here is what Steve's research revealed:

Created in 1941 as America entered World War II, the A57 Multibank engine was born out of the necessity for a rear-mounted tank engine to be developed and produced, in the shortest time possible, for use in both the 109 examples built of the M3A4 Medium Tank, and the 7,499 examples built of the successor M4A4 Medium tank, each of which had lengthened hulls to accommodate them.

In order to use existing tooling, five Chrysler 250.6 cu in L-head inline six cylinder engines were arranged around a central shaft, producing a unique 30-cylinder 1,253 cu in engine in a relatively compact but heavy package. The crankshafts were fitted with gears, which drove a sun gear arrangement. With iron block and head, it featured Carter TD-1 carburetors and 6.2:1 compression ratio, for an output of 370 hp at 2400 rpm. Most of the tanks equipped with these engines were supplied to Allied countries under America's Lend-Lease program.

In the February 1944 issue of the magazine Popular Science, an advertisement by Chrysler claimed the A57 could still move the tank it was fitted in even if 12 out of its 30 cylinders were knocked out.

The M4A4 was largely supplied to the British, the US preferring the M4A3 with the more conventional Ford GAA V8 engine, and restricting their M4A4s to overseas use.

### Cruise Night Schedule?

You may have noticed the absence of our Cruise Night schedule in this issue of The Fifth Wheel newsletter. Don't be concerned. It's still exists on our website at [www.corvair.org/chapters/lvcc/calendar.htm](http://www.corvair.org/chapters/lvcc/calendar.htm)

It remains basically the same from month-to-month, so there's really no need to reprint it here.

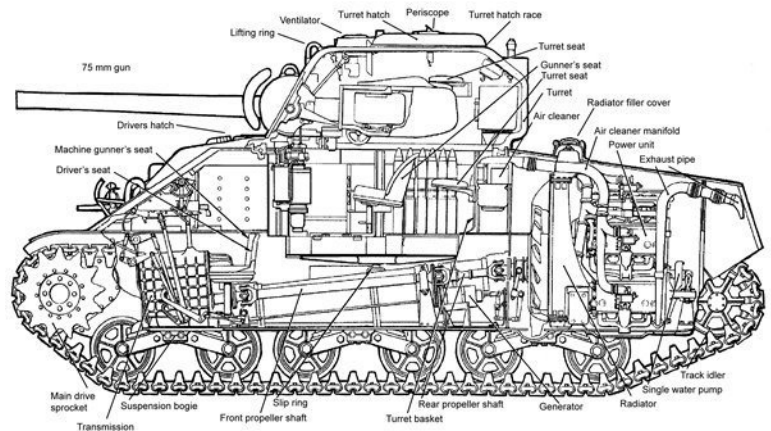
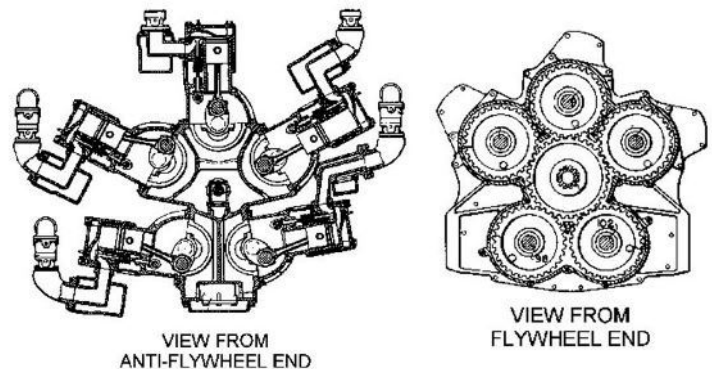

## LVCC Classified Ads!



**Corvair Parts Garage Sale!** Date: Saturday September 23, 2017. Location: Klingaman Residence, 2063 Ridge Road, Bangor, PA 18013. Time: 9 AM to 3 PM. Items includes starters, alternators, spindles and brake drums, engine sheet metal, and several late-series manual transaxles. Twenty-two (22) pair of 140 heads for sale. Eight engines with ID Codes W, RH, RK, RL, RM and RZ. Five crankcases. There are two heaters, one for a Corvair and one for a dune buggy. If you are missing an engine part, or suspension part, I might have it. Also, the following is a list of engines and case halves that have to move. Best offer pricing. All items to be picked up. For more information, email Ken Klingaman at [stingerken@earthlink.net](mailto:stingerken@earthlink.net)

**For Sale:** For Sale: 1964 Corvair Monza 2-door coupe. 110 hp engine. Powerglide automatic transmission. Goldwood yellow exterior. Black vinyl and deep-weave fabric interior. Great condition. 77,000 miles. \$7,500. Contact Wayne Troxell, Andreas, PA. (570) 386-4347.



**For Sale:** 1969 Corvair 500 2-door coupe. 110 hp engine. Powerglide automatic transmission. Garnet red with black interior. Zero rust. Excellent condition all around. 48,000 miles. Hellertown, PA. \$10,000. Larry Lewis, Hellertown, PA (610) 209-0297.

**SOLD!** We are happy to announce that Ron Peles sold his 1966 Chevrolet Corvair Monza Sport Coupe. The new owner is a member of the New Jersey Association of Corvair Enthusiasts. Ron remains in the Corvair fold however. His second Corvair is a 1965 Corvair Corsa convertible which has been in his possession for decades!

## Clark's Corvair Parts®

400 Mohawk Trail, Shelburne Falls, MA 01370  
(413)625-9776 [www.corvair.com](http://www.corvair.com)



## Our 43rd Year!

### Get the 2013-2018 Catalog

MAIN CATALOG - Over 420 Pages, over 15,000 parts  
SPECIALTY CATALOG - Over 220 pages  
SUPPLEMENT - Price list has over 40 pages

*Clark's Corvair donates door prizes for our meeting at Das Awkscht Fescht.*



## ***Local Car Shows and Other Events***

### ***Saturday September 09, 2017 :::: Car Show & Party***

Location: 2943 Route 212, Springtown, PA (gps hellertown 18055). Limited to 1969 and older cars & trucks. Bands, beer, pinup contest, bicycle show, valve cover racing, DJ, pin striping, 50/50, food from Grumpy's, show shirts, custom hand made trophies. Rain date September 10. Email dals@comcast.com Event info <https://www.facebook.com/events/1426446770761190/> gasket goons

### ***Sunday September 10, 2017 :::: Fiberglass & Steel All-Chevy Show***

Location: Steel Stacks Arts Complex, Bethlehem, PA. Time: 9:30 AM to 3:30 PM. Rain or Shine. Trophies for top 20 Chevy and top 20 Corvette, etc. 50/50, door prizes, dash plaques, DJ. Price \$20 day of show \$20 Host: Allentown Area Corvette Club Info: kevin minnich (610) 530-0923. Email: aaccnewsletter69@gmail.com. [www.AllentownCorvetteclub.org](http://www.AllentownCorvetteclub.org)

### ***Sunday September 10, 2017 :::: 13th Annual Franconia Park Car Show & Flea Market***

Location: Franconia Park, Franconia PA. Enter the park from Godshall Road. Time: 9 AM to 2 PM. Rain date Sunday September 17. Prices: Vehicle Reg. \$15, Flea Market \$10 (Bring your own tables). Raffles, door prizes, DJ, 50/50, trophies. Host: East Penn Modifiers Club. Info: Jim Hunsberger (215) 313-7033 or Chris Mills (267) 745-3626.

### ***Saturday September 16, 2017 :::: Fall Classic at Clark's Corvair Parts***

Location: Clark's Corvair Parts, 400 Mohawk Trail, (Route 2), Shelburne Falls, Massachusetts. Time: 9 AM to 3 PM, rain or shine. Car show with 100 Corvairs, tours, dash plaques, trophies, raffles, food. Buy parts 10% off with cash, 5% off with credit card or check. Host hotel is Red Roof Inn South, Deerfield, (800) 733-7663, say "Bay State Corvairs" for \$83.99 rate. Alternate hotel is the Hampton Inn, (413) 773-0057, no discount. For additional information, visit [baystatecorvairs.org](http://baystatecorvairs.org) or contact Ray Bombardier, (508) 473-7026, [bomma@comcast.net](mailto:bomma@comcast.net).

### ***Saturday, September 16, 2017 :::: Car & Motorcycle Show in Palmerton***

Location: Jerusalem Evangelical Lutheran Church, 500 Church Rd, Palmerton, PA 18071 Time: 9 AM to 3 PM. Rain date September 17. Trophies. Contact Mary Wood [mwood443@gmail.com](mailto:mwood443@gmail.com)

### ***Saturday September 16, 2017 :::: 2nd Annual Cruis'n for Christ Car Show***

Location: St. Peter United Church of Christ, 1920 Ridge Road, Knauertown, PA 19465. Time: 10 AM to 2 PM. Price: \$15 day of show. Limited to vehicles 25 years or older. Awards, food, music. Contact: (484) 374-0667 or [jetbike@windstream.net](mailto:jetbike@windstream.net)

### ***Sunday, September 17, 2017 :::: All Air-Cooled Gathering Show***

Location: Flanders Swim and Sport Club 272 Emmans Rd, Flanders NJ. Time: 8 AM to ~ 3 PM. Price: \$15 day of show. Food, bar, entertainment and more. The Air Cooled Gathering is actually a three-day Volkswagen camping event capped with a car show on Sunday. Corvairs are certainly welcome and have their own class in the show with trophies. [www.allaircooledgathering.com](http://www.allaircooledgathering.com)

### ***Sunday September 17, 2017 :::: Cars & Coffee Lehigh Valley***

Location: Steel Stacks, 101 Founders Way, Bethlehem, PA 18015. Time: 8 AM to 12 PM. All makes/models. Special theme: Trucks, Jeeps & SUVs.

### ***Saturday September 23, 2017 :::: Corvair Day at Hershey***

Location: AACA Museum, 161 Museum Dr, Hershey, PA 17033. Corvair car show, driving event, museum activities, vending, raffles, awards. Rain date September 24. For registration and schedule contact Earl Holmes, (717) 991-7341 or [earlzgames@comcast.net](mailto:earlzgames@comcast.net)

### ***Saturday September 23, 2017 :::: A&A Car Show / Customer Appreciation Day***

Location: A&A Auto Parts, 4630 Broadway, Tilghman Square Shopping Center, Allentown, PA 18104. Time: 9-4. Rain or shine. Music & food. Info: Jason (610) 391-9660. [jdwagaman@key-stone.com](mailto:jdwagaman@key-stone.com)

(Continued on page 10)

## ***Car Shows and Other Events (continued)***

### ***Sunday September 24, 2017 :::: Birdsboro Car Show***

Location: Daniel Boone High School, Rt. 345 (501 Chestnut Street), Birdsboro, PA. Take Route 724 and follow the signs. Time: 9 AM to ? Price: \$12 day of show. Rain or shine. 6 cash drawings. Door prizes. 50/50. Chinese auction. Sponsor choice awards. Food.

### ***Sunday September 24, 2017 :::: 5th Annual Winding Brook Farm "Maze" Car Show***

Location: Winding Brook Farm, 3014 Bristol Road, Warrington, PA. Time 11 AM to 3 PM. Rain date Saturday September 30. Price: \$15. Raffles, DJ, door prizes, 50/50, trophies, hay maze & corn mazes. Wide variety of food. Host: East Penn Modifiers Club. Info: Jim Hunsberger (215) 313-7033.

### ***Sunday September 24, 2017 :::: Fall Cruise-in at Wind Gap Chevy-Buick***

Wind Gap Chevy-Buick, Route 512, Wind Gap, PA. Time: 9 AM to 2 PM. Rain or shine. Price: \$5 donation for Vietnam Veterans Group. DJ, coffee & donuts, food, awards. Host: Wind Gap Chevrolet. Presented by Slate Belt Corvette Club. Info: (610) 841-6403 or [www.slatebeltCorvetteclub.com](http://www.slatebeltCorvetteclub.com)

### ***Sunday October 01, 2017 :::: UBSRA 35th Annual Rod Run***

Location: Silver Creek Athletic Association, Routes 412 and 212, Springtown, PA. Time: 9 AM to 3 PM. Limited to 1963 and older vehicles. Price: \$15 day of show. Spectator parking is free, general admission \$5 adults and children 12 & under free. Info: (215) 258-5719 [www.ubsra.com](http://www.ubsra.com)

### ***Sunday October 08, 2017 :::: North Catasaqua Autumnfest & Car Show***

Location: North Catasaqua Park, 701 Grove Street, North Catasaqua, PA 18032. Time: 11 AM to 5 PM. Rain date October 14. Food, live music, craft & flea market. Bring toy or money donation for Toys for Tots. Info: Marc (484) 560-1938

### ***Saturday October 14, 2017 :::: Annual Fall Q-mart Car Show***

Quakertown Farmers Market, 201 Station Rd, Quakertown, PA 18951. Front parking lot. Time: 9 AM to 1 PM. Rain date Sunday October 15. Door prizes, DJ, raffles, trophies. Host: East Penn Modifiers Club. Info: Jim Hunsberger (215) 313-7033 or Chris Mills (267) 745-3626

### ***Sunday October 15, 2017 :::: Oktoberfest Car Show***

Location: Wind Gap Borough Park, 545 West Street, Wind Gap, PA. Time: 10 AM to 3 PM. Price: \$12 day of show. German music, pig roast, old fashioned cake walk. Info: Ed Gallagher (610) 657-6196. [ksbvet@ptd.net](mailto:ksbvet@ptd.net)

### ***Sunday October 29, 2017 :::: 41st Annual Kempton Car Show***

Location: Kempton Community Recreation Center, 83 Community Center Drive, Kempton, PA 19529. Time: 8 AM to ~3 PM. Rain or shine. Price: \$10 day of show. Food, car corral, indoor flea market, outdoor flea market. Info: Clarence Getz, (610) 377-6130. [www.buickfreespirit.org](http://www.buickfreespirit.org)

---

## ***LVCC Officers***

President: Dennis Stamm Phone: (610) 926-4723 Email: [dmstamm@comcast.net](mailto:dmstamm@comcast.net)  
Vice Pres: Fred Scherzer Phone: (484) 948-5142 Email: [jukeboxman44@gmail.com](mailto:jukeboxman44@gmail.com)  
Secretary / Treasurer: Richard Weidner. Phone: (610) 502-1414 Email: [anythingvair@yahoo.com](mailto:anythingvair@yahoo.com),  
Newsletter & Website Editor: Allan Lacki. Phone: (610) 927-1583 Email: [redbat01@verizon.net](mailto:redbat01@verizon.net)

---

***Next Meeting: Wednesday 09/27/2017***

---