



the fifth wheel

AUGUST 2018

[HTTP://WWW.CORVAIR.ORG/CHAPTERS/LVCC](http://www.corvair.org/chapters/lvcc)

ESTABLISHED 1976

Inside this issue	
Next LVCC Meeting: Wednesday 09/26/2018	1
Valley Ramblings Das Awkscht Fescht	2
Randy's Corvair Up On the Lift, by Randy Kohler	2
VCCA Seeks Corvairs, by Allan Lacki	2
LVCC Dues Are Due! August 2018 to July 2019	2
Das Awkscht Fescht Photos, by Steve Hurst	3
It's Too Loud! by Ray Coker	5
Rich Green Solves Starter "Gronk"	5
CORSA Convention Photos	6
Charlie Potts Points & Condensers	7
2018 CORSA Convention Article, by Allan Lacki	7
Local Car Shows & Other Events	8
LVCC Classified Ads Cars & Parts	10
LVCC Officer Contact Information	10



Next Meeting! Wednesday, September 26, 2018

LVCC Meeting Information: Time 7:30 PM. Place: Lehigh and Northampton Transportation Authority Headquarters (LANta), 2nd Floor Meeting Room, 1060 Lehigh Street, Allentown, PA 18103. Latitude : 40.587607 | Longitude : - 75.474405. Bring a guest!

Don't get locked out. If you arrive late, the main door of the LANta office building may be locked. But the facility is open around the clock, so ask one of the garage employees to direct you to the second floor.



The Fifth Wheel is published monthly by Lehigh Valley Corvair Club Inc. (LVCC), a chartered chapter for the Corvair Society of America. We accept articles of interest to Corvair owners for publication. Classified advertising of interest to Corvair owners is available free of charge to all persons. Commercial advertising is also available on a fee basis. For details, email our newsletter editor, Allan Lacki, redbat01@verizon.net.

Valley Ramblings

by Randy Kohler

Das Awkscht Fescht Report. The 55th anniversary edition of the August Festival is now in the books, and a humid one it was! The Friday show was pretty much a rain-out, flooding some of the lower areas of the park and making the grass areas muddy and slick.

Saturday the sun came out and there was a pretty good turn-out of hearty souls who didn't cringe at muddy tires! The flea market and car corral were really wet and scarce of vendors. The food and music were good as usual and they staged a spectacular fireworks display to a large appreciative crowd! Saturday we received a dash plaque with the featured car, the Packard on it and an auto fire extinguisher.

Thankfully, the brilliant sun on Saturday dried the show field a bit for Club Day on Sunday, and we had a nice turn-out of 41 of our favorite marque. I always enjoy this show, getting to see Corvair friends that I only get to see once a year!

I especially missed long time LVCC member and close friend Dennis Weaver who passed suddenly last fall. For over 30 years he would bring a tent, card table and help park cars. He will certainly be missed and we dedicated a moment of silence in his memory. Thanks go to his wife Cathy for loaning their table to us for under the tent!

Our Sunday Corvair display consisted of 15 late closed, 10 late open, 8 early

closed, 4 early open and 4 forward control (all Rampsides). Most owners were from PA (38) NJ (2) and DE(1). We had a stable of really nice cars that did the nameplate proud! Sunday participants received a nice beach towel in addition to their dash plaque.

I wish to thank the festival committee for all of the effort that they put forth, Gary Ganssle, Dennis Stamm and Dick Weidner for set-up and parking, and Conner Stamm ,(Dennis and Mary-Ann's 11 year old grandson) who handed out raffle tickets and helped at the drawing. Conner is a future car nut and Corvair owner for sure! It wouldn't happen with-out them.

Also, a big thanks to Clark's Corvair Parts for the "goodie box" they send every year with parts, gift certificates and catalogs for door prizes.

And last but not least, thanks to LVCC members who donated goods also. We hope to see you next year, August 2,3, & 4, 2019 for the 56th annual festival. It will feature Chrysler products, but our Corvairs will always be the main attraction!

Randy's Corvair Up On the Lift! My car is getting all new brakes, (lines, master and wheel cylinders, shoes etc) at a friend's garage. LVCC President Stamm said he would come up and give us advice on the job. He said in order to make the job easier, he drops the whole front cross-member as well as

the fuel tank. Frankly, I thought he was nuts! (sorry Dennis).

He drove right up to New Tripoli where my project is being done and told us how to easily get out the crossmember. I bet it was on the floor in 45 minutes! And no bolts snapped with his soaking and pounding on the bolt with a large drift! Now everything is readily accessible and easy to install! Boy, you shouldn't doubt the big dogs!!!

I also had Dennis check around under the car and he pointed out some bushings, grommets and boots that should be replaced. I can't thank him enough for giving of his time and knowledge for the cause!

VCCA Seeks Corvairs

The Vintage Chevrolet Club of America (VCCA) will be holding its 4th Annual Eastern National Meet. The dates are August 23 through 25 and the host hotel is the Holiday Inn at Morgantown, PA.

The owner of the Holiday Inn just so happens to own the Class Auto Mall located just next door and the two facilities are connected by a hallway from the hotel lobby.

Among other things, the meet will include an extensive number - possibly hundreds - of Chevys on display inside the Mall. The owner's own collection



LVCC Dues are Due! If you haven't already done so, please pay up for August 2018 through July 2019. Price? Still only \$10 for CORSA Members. \$15 for all others.

You can pay at our September meeting or mail a check to LVCC Secretary / Treasurer Dick Weidner, 2304 Main Street, Northampton, PA 18067.

Corvairs at Das Awkscht Fescht!

Photos provided by Steve Hurst



The LVCC tent provided all-day shade.



Kyle Regan and Dale Parkhurst Corvairs in front.



Mike Slotwinski with flyers for 1st State Show.



Paul Shade's immaculate 1960 is here with lates.



Corvair engine lids, open for public inspection!



Rich Greene and friends.

Corvairs at Das Awkscht Fescht!

Photos provided by Steve Hurst



Dave Smith's green Corsa at front of the line.



Early morning photo before the field was filled.



Dave Stein's '69 next to Dave Smith's Corsa.



Carl Moore, Ray Coker, Curt & Patricia Stone



One of two 1964 Spyder convertibles.



Two of the three Rampides on display this year.

of unusual barn-find antique cars will also be on display. The whole place is air-conditioned, so folks can walk about the cars in comfort.

Like CORSA, the VCCA limits participation to its own members, so to join the fun, you need to join VCCA. But there is nothing to restrict non-members from putting their own cars on display out in the huge outdoor parking lot. The Class Auto Mall was once a major shopping mall, so space is ample for any kind of car event.

Erv Steinly Jr., the local regional director of the VCCA, would be most gratified if a number of Corvair owners put on their own car show in the parking lot during the VCCA event. After all, Corvairs are Chevies, too. For more information, you contact call Erv at (484) 818-1487 or Aces1957@comcast.com

It's Too Loud by Ray Coker, NJACE

If the mufflers on your Corvair don't allow you to use the radio... it's too loud. If the mufflers on your Corvair don't allow you to use a cell phone... it's too loud. If the mufflers on your Corvair don't allow you to talk to your passenger without leaning over... it's too loud. If the mufflers on your Corvair make all the neighbors' dogs bark, drown out emergency vehicle sirens, make you not notice jets doing low flyovers near you or drown out guns being fired at you for waking the baby... it's too damn loud.



Author Ray Coker's Corsa, "Fast Orange".

Some of the examples above relate to the current exhaust system on my Corvair. It's too... you got it, LOUD.

When I purchased my Corvair 14 years ago it had a nice custom dual exhaust that fit and sounded great. It was also ceramic coated which promised a long life and a constant silver color with no tarnishing. About eight years ago I noticed it showing some signs of use and decided to have it ceramic coated again. The company that coated it the first time would not warranty it because I was not the original purchaser. No big deal, I had it coated again.

After 14 years it was beginning to get louder with each use and even though the outer finish was still somewhat okay I felt the mufflers inner gizzards were wearing out so I decided it needed a whole new exhaust system, a system matching the one I was replacing because it was PERFECT. The hunt was on for mufflers matching the ones I had in length, width and thickness.

I spent a couple of months searching high and low, turning over every rock I walked by, calling and visiting muffler shops, doing internet research and finally buying two mufflers at Surplus City that were labeled "quiet" and could be made to fit my Corvair. Guess what... they are too loud.

I recently searched Summit Racing for mufflers and found two that I knew I could make fit even though they were not the exact ones I have been searching for. I placed an order for them.

A couple of hours later while still searching the internet I found a muffler guy in Henderson, Nevada, who advertised that he has been in the business for 46 years. I sent him an email describing the exact mufflers I wanted by length, width and thickness. Much to my astonishment he replied he could get what I was looking for, all I needed was to stop by his shop and

he would get them for me.

I emailed him back explaining I was in Pennsylvania and could he share the manufacturer and part number and I would see if I could find some near me. Sure, he said, just go to Summit Racing and look at part # AP 700068. WHAT?????

I did and it's the exact muffler I have been searching for. I cannot believe it. After months of research all it took was one person to point me in the right direction. It's too loud... NOT ANY MORE!

Rich Greene Solves Starter "Gronk"

Those of you who have been following our meeting notes may recall that Rich Greene was having problems with the starter in his Rampside. When he turned the key to start the engine, the starter gear would clash with the ring gear making a mighty loud "Gronk!"

Rich tried everything to fix it, or at least he thought he did. New starter, new solenoid, new bellhousing; but nothing seemed to work.

Then one day, while perusing the Clark's Corvair catalog, he came across a starter relay kit. Here is what it said:

*Clark's Starter "Relay Kit"
Starter always start? Want to be sure?
Does your Corvair solenoid sometimes just click event though you've replaced it and checked the wires? Does your starter just barely turn over when hot? You receive a relay with all the wires and complete instructions. The relay can be installed inside the engine compartment by the regulator or on the other side of the firewall (out of sight). The relay sends a full 12V to the starter every time. "Relay Kit" C2056R 4 pounds. \$37.75.*

Rich decided to give it a try. He bought the kit, installed it, but lo and behold, the relay was defective! So,

CORSA Convention Photos



A small portion of the Corvairs at the host hotel.



1960 Corvair Super Monza from the CPF.



Side trips included a stop at the trolley museum.



LVCC member John Egerton at the autocross.



Raffle car was won by John Bodnar of Oswego,



Dinner Cruise. Pittsburgh skyline at dusk.

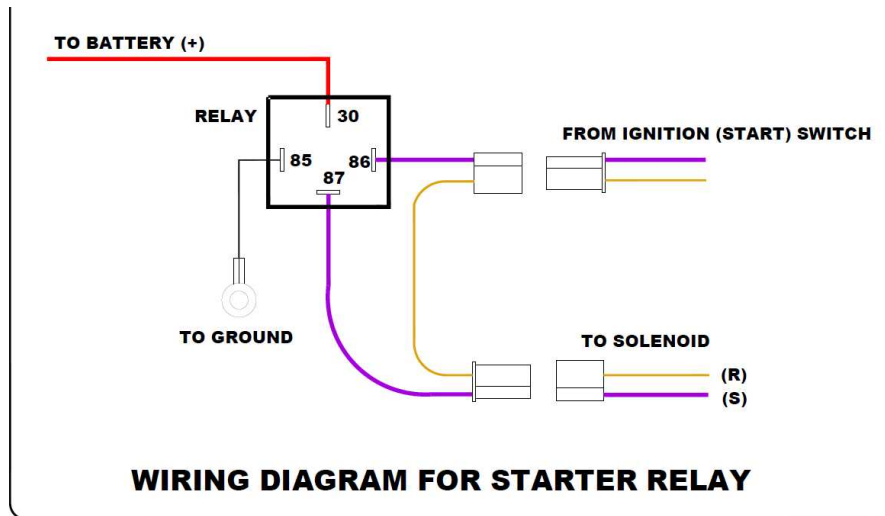

we replaced it with one from his friendly local auto parts store. No more “gronk.” The problem was immediately cured and, ever since, the Greenbrier has been starting up every time without the obnoxious noise.

Getting back to that ad in the Clark’s catalog.... Actually, the kit doesn’t do anything to help the starter motor. Rather, it provides a means of providing a full 12 volts to the starter solenoid - without any voltage drop from the battery.

Ordinarily, the solenoid gets its juice from a long circuit that goes from the battery, up through the ignition key and then back to the solenoid. That’s a recipe for significant voltage drop, especially considering all the snap connectors in-between.

With the relay kit, that long circuit no longer carries the current necessary to activate the solenoid. Instead, it is used to trigger the relay, which in turn, energizes an otherwise direct connection between the battery and the solenoid. With the relay located in the engine compartment just a few feet away from both the battery and solenoid, there is no measurable voltage drop and the solenoid gets all the power it needs to engage and disengage the starter without clashing the ring gear.



Charlie Potts Points and Condensers

Charlie Potts, VCCA’s carburetor expert, stopped by the LVCC tent at Das Awkscht Fescht and dropped-off some goodies for us to raffle. Three sets of NOS Delco ignition points and one NOS Delco condenser.

These items sell for \$7 to \$13 apiece on eBay and Amazon so this was a nice donation on Charlie’s part.

Charlie also included two admission tickets for this year’s Duryea Day show. They are worth \$8 apiece. Those of you who are on our email list already know about this offer. It was quickly snagged by Joe Lynch!

You may recall that Charlie donated one of his beautiful rebuilt Carter YH carburetors to us last year, which we auctioned off on eBay. Thanks again Charlie!

2018 Convention by Allan Lacki

Joanie and I went to the 2018 CORSA Convention in Pittsburgh in our trusty ‘66 Monza. We did the economy run, rally, autocross, dinner cruise and a visit to the Pennsylvania Trolley Museum. I also attended the CORSA

Board Meeting.

Monday Board Meeting. Your CORSA Board of Directors holds monthly teleconferences throughout the year and conducts a formal in-person meeting at the annual convention. This year, representatives from the Chicago and San Diego chapters gave presentations on their plans for the 2019 and 2020 conventions. Presentations were also made by the CORSA Executive Secretary, CORSA Treasurer, CORSA Merchandising Director, and CPF President. Other topics of discussion included CORSA’s insurance policies, scoring for a proposed Dollie Cole Award, collection of the annual \$35 chapter fee, reduction of postage costs, etc. In the coming months, we’ll be rolling out some changes that we agreed upon at the board meeting.

Tuesday Dinner Cruise. Tuesday was more-or-less a free day for Joanie and me, so we spent nearly three hours with my cousin Gloria - a resident of nearby Mount Lebanon - whom I hadn’t seen for ten years or so. Then I spent the afternoon transcribing lap times for the NECC time trials and evaluating CORSA chapter websites for the annual CORSA website of the year award. As evening approached, we hopped onto one of the several school buses that transported us to dock for the Gateway Clipper Dinner Cruise. The river boat took us up and down the Allegheny, Monongahela and Ohio Rivers for more than two hours. The food was good and we were treated to views of many points of interest including the historic bridges that tie Pittsburgh together.

Wednesday Economy Run. The economy run and rally routes avoided the city and consisted of back country roads through the hills and dales of western Pennsylvania. Here and there, we came across sites where construction crews were installing natural gas pipelines for the many fracking projects that dot the landscape. But aside from that, both routes were scenic with the kind of changes in elevation and curves that make for fun driving in a Corvair.

(Continued on page 9)

Local Car Shows and Other Events

Saturday August 18, 2018 :::: 20th Annual Under the Stars Car Show

Location: Perkasio Old Town Center, 620 W. Chestnut St, Perkasio, PA 18944. Time: 5 PM to 8 PM. Price: \$20 day of show. Enjoy 400+ antique, classic and custom vehicles lining Perkasio's beautiful and historic town center. Food, music and a wonderful community night out for the whole family. Sponsored by: Perkasio Borough and Perkasio Towne Improvement Association. Contact: (215) 257-5065. <http://perkasioborough.org/our-events/under-the-stars-car-show/>

Saturday August 18, 2018 :::: 10th Annual Wheels of Faith Car Show

Location: Faith Lutheran Church, 3255 MacArthur Road, Whitehall, PA 18052. Time: 8:30 AM to 3 PM. Price: \$14 day of show. Rain date Sunday August 19. Food, oldies music, 50/50. Phone: (610) 435-0451.

Sunday August 19, 2018 :::: 22nd Annual Tremont Fire Company Car & Truck Show

Location: Tremont Elementary Ball Field, 139 Clay Street, Tremont, PA. Time: 9 AM to 3 PM. Price: \$12 day of show. Rain or shine. Food, music, trophies. 21 classes including one for compact cars. Contact (570) 695-3915 or (570) 617-1299

Sunday August 26, 2018 :::: Reinholds VFW Car Truck & Bike Show

Location: 250 Brunners Grove Road, Reinholds, PA. Time: 9 AM to 3 PM. Price: \$10. Rain date September 2. 6th annual event. Over 475 entries last year. Food, trophies, music, door prizes. Contact: Ted (717) 336-7242 or nutseynut714@yahoo.com

Sunday August 26, 2018 :::: Al Laskey Memorial 27th Annual Auto Show

Location: Perkiomen Valley School District Campus, Rt. 29 & Trappe Road, Graterford, PA. Price: \$15 day of show. Time: 8 AM to 3 PM. Independent judging with trophies for top 75 cars. Open format layout. No Corvair class. No canopies on the lot. Hosted by the Perkiomen Township Fire Company. For more info, call Jeff Parlee (610) 489-4986 (evenings only) or Bill Paterson (484) 614-4698 (day or evening).

Saturday September 1, 2018 :::: 54th Annual Duryea Day

Location: Boyertown Community Park, 419 South Madison Street, Boyertown PA. Time: 9 AM to 4 PM. Price: \$15 day of show. Flea market and car corral spaces available. Duryea Day is a well-established event that attracts hundreds of cars, trucks and motorcycles from all decades. Music, great food and children's entertainment make this a family-friendly and affordable event. Shuttle service to visit the Boyertown Museum of Historic Vehicles is included in price. Presented by the Pottstown Region A.A.C.A and the Boyertown Museum of Historic Vehicles. Visit www.BoyertownMuseum.org or contact (610) 367-2090 or mail@boyertownmuseum.org

Monday September 3, 2018 (Labor Day) :::: Conrad Weiser Lions / Stewart's Root Beer Show

Location: Robesonia Play Ground, East Robeson Street, Robesonia, PA. Time: 7:30 AM to 4 PM. Price: \$20 day of event. Live music by Flamin' Dick & the Hot Rods from 1 PM to 4 PM. Food, refreshments, door prizes, 50/50, etc. No canopies or tents please. Awards via people's choice. Questions? Brian Keppley (610) 670-2835 or email beekepp9@gmail.com

Saturday September 8, 2018 :::: 8th Annual United Methodist Car Show, Gilbertsville

Location: New Hanover United Methodist Church, 2211 Swamp Pike, Gilbertsville, PA 19525. Time: 9 AM to 2 PM. Rain date & time: Sunday September 9 beginning 1:30 PM. Price: \$15 day of show. Awards, auctions, door prizes, food & music. www.newhanoverumc.com

Saturday September 8, 2018 :::: Gasket Goons Hot Rod Bash

Location: Silver Creek Athletic Association, 2943 Route 212, Springtown, PA 18081. Time: 8 AM to 7 PM. Price: \$10 per person. Limited to '69 and earlier cars and trucks. Trophies at 3 PM. Bands, beer, food, swap meet, awards, pinstripping, pin-up contest. Valve cover races at noon. Contact: dals@comcast.net Internet: <https://www.facebook.com/gasket.goonspa/>

Sunday September 9, 2018 :::: Strausstown Lions Antique Auto Show & Flea Market

Pre-registration required. Your registration form and check must be received no later than September 3. Price: \$10. Location: Strausstown Playground, 10 Wilson Avenue, (off Route 183), Strausstown, PA 19559. Time: 9 AM to 3 PM. Judged show with 37 classes (but no Corvair class). Contact: (610) 858-8713 or www.strausstownlionsclub.com

(Continued on page 9)

Local Car Shows and Other Events (cont'd)

Saturday, September 15, 2018 :::: Salem E.CC Church 10th Anniversary Car Show

Location: Salem E.C. Church, 2150 Old Route 22, Lenhartsville, PA 19534. Time: 11 AM to 3 PM. Price: \$20 day of show. Live music, silent auction, pig roast, ice cream, farm tractor display, kids activities. For more info, call (610) 562-5033. www.fb.com/WeAreSalem.

Saturday September 22, 2018 :::: Corvair Day- Hershey, PA [Central Pennsylvania Corvair Club]

Location: AACA Museum, 161 Museum Dr, Hershey, PA 17033. Registration opens: 8 AM. Rain date: September 23. Price: \$12 day of event and includes admission to the museum. Also includes car show, door prizes, scavenger hunt inside the museum, bake sale and 50/50 drawing. Event will be followed by a dinner at the Skyline Diner. Point of contact is Earl Holmes, (717) 991-7341, earlzgames@comcast.net.

Sunday September 23, 2018 :::: 21st Anniversary Car Show, Birdsboro

Location: Daniel Boone High School, 501 Chestnut Street, Birdsboro, PA 19508. Time: 9 AM to ? Price: \$12 day of show. Door prizes, 50/50, Chinese auction, food and music. Sponsor choice awards. Conducted by The Women's Club of Birdsboro. Contact: Phyllis at (484) 363-0670.

Also, be sure to visit the Corvair Society of America website to see events being conducted by our neighboring CORSA chapters! Go to www.corvair.org and click on "Events".

(Continued from page 7)

The economy run was well organized. The instructions were clear and concise. In accordance with CORSA's new economy run rulebook, time spent at the checkpoint was measured and was not counted against the run's time limit. Convention Chairman Jim Weppelman did a last minute run at 4 AM to make sure that the route had no detours. (That's devotion!) And as far as we could tell, the event went off without a hitch. Joan and I managed to get 26.9 mpg for third place in the 2-carb / manual transmission class.

Thursday Rally. The rally route included a couple of nice surprises. By now, you may have heard that it led right past the old Don Yenke Chevrolet dealership, home of the Yenke Stinger. But it also included a drive past the barbershop in Canonsburg, PA where Perry Como used to cut hair before his singing career took off. The street is aptly named "Perry Como Avenue."

Sometimes, CORSA rallies require the navigator to anticipate trick instruc-

tions, such as reading ahead two steps to figure out the next place to make a turn. But there was none of that funny stuff this year.

On the other hand, some of the novices were tripped-up by ideas that were new to them. For example, the route included two "transit zones" - sections of the route that were not included in the navigators' time-and-distance calculations. Actually, transit zones make perfect sense because enable the scorekeepers to filter out segments of the route that have traffic problems that would otherwise impact competitors unfairly.

Some of the competitors didn't notice that the paperwork included a separate answer sheet where navigators were required to compute the miles and durations for each segment of the rally. The answer sheet was stapled toward the back of the instruction packet and some people didn't see it until it was too late. Luckily, Navigator Joan caught on quickly. We managed to come in 8th overall in the rally.

Friday Autocross. There were a lot of "DNFs" this time! The parking lot space accorded to the organizers was small and, as a consequence, the circuit was very tight. It included a switchback, too, and the resulting sea of traffic cones eluded many drivers.

To familiarize themselves, autocross drivers typically walk a course several times before the competition begins. That way, they can identify all the traffic cones and plan their way around them before they actually go out for timing. Woe came to those who skipped this crucial step at this year's event!

I stink at autocross driving, so I'm sure my times were terrible. Nevertheless, I got two good timed runs with only one DNF. Slow but sure....

Joan and I went to the banquet Friday night but skipped the car display on Saturday. We drove back home instead, savoring the memories of another great CORSA convention.

LVCC Classified Ads!



For Sale: 1964 Corvair Monza 2-door coupe. 110 hp engine. Powerglide automatic transmission. Goldwood yellow exterior. Black vinyl and deep weave fabric interior. Great condition. 77,000 miles. \$7,500. Contact Wayne Troxell, Andreas, PA. (570) 386-4347

For Sale - Make Offer: 1964 deck lid. 1964 left convertible door. Two 1964 rear cross springs. 1964 used wheel opening moldings. 1964 used rocker panel moldings. Various 1962 13" spinner wheel covers. Various full 13" wheel covers. 1962 right & left front grill moldings (pitted). Four 1962 13" rims with belted tires. Late drums (non-finned). Early door side glass. 1961 engine, rear, trans for parts. Various starter parts. 1965 used single exhaust pipe. 1964 Turbo block with cam and crank. Call or email Fred Scherzer. (484) 948-5142. jukeboxman44@gmail.com

For Sale: 1964 Corvair Sedan. Red with black interior. 2-carb engine with 4-speed transmission. Described as a "solid driver." Ran last year but rough. Price: Around \$3500. Includes many spare parts including a complete engine and turbo set-up, depending on price. Car is near Collegeville, PA. Contact Chris Filippini. (610) 564-1658 after 4:30. Please leave a message if no answer. Or email filippinichris@me.com

Clark's Corvair Parts®

Our catalog lists over 15,000 parts for your Corvair. We carry engine parts, body panels, upholstery and much more! There are 1,000's of reproduced items available, pages of technical information and lots of other helpful hints.



Clark's Corvair Parts® 400 Mohawk Trail, Shelburne Falls, MA 01370
(413)625-9776 www.corvair.com email: clarks@corvair.com

Clark's supports LVCC by donating gifts every year for our door prizes at Das Awkscht Fescht.

LVCC Officers

President: Dennis Stamm Phone: (610) 926-4723 Email: dmstamm@comcast.net
Vice Pres: Fred Scherzer Phone: (484) 948-5142 Email: jukeboxman44@gmail.com
Secretary / Treasurer: Richard Weidner. Phone: (610) 502-1414 Email: anythingvair@yahoo.com,
Newsletter & Website Editor: Allan Lacki. Phone: (610) 927-1583 Email: redbat01@verizon.net