



the fifth wheel

DECEMBER 2020

[HTTP://WWW.CORVAIR.ORG/CHAPTERS/LVCC](http://www.corvair.org/chapters/lvcc)

ESTABLISHED 1976

Inside this issue

<i>Remembering Warren LeVeque, by James Rice</i>	2
<i>Mystery Engine Tap, by Red Monza</i>	2
<i>Warren's Corvair Creations. A Photo Gallery</i>	3
<i>Corvair-Powered Super Vee in Lancaster, PA</i>	4
<i>Blame It on Fiat! by Allan Lacki</i>	5
<i>Corvair Classified Ads by Larry & Bob</i>	7
<i>Tubular Grilles Old Accessories</i>	7
<i>1971 Crossword Puzzle by Dave Newell</i>	8
<i>Final Dues Reminder Your On Our List!</i>	10
<i>This Month's Puzzle Solution</i>	10
<i>LVCC Officer Contact Information</i>	10



Next LVCC Teleconference - January!

We'll be having our next teleconference on Wednesday, January 27, 2021. Meanwhile, we'll keep you entertained with our regular monthly newsletters. And as always, reach out to us if you need tech advice or have questions about keeping your Corvair alive.



The Fifth Wheel is published monthly by Lehigh Valley Corvair Club Inc. (LVCC), a chartered chapter for the Corvair Society of America. We accept articles of interest to Corvair owners for publication. Classified advertising of interest to Corvair owners is available free of charge to all persons. Commercial advertising is also available on a fee basis. For details, email our newsletter editor, Allan Lacki, redbat01@verizon.net.

Remembering Warren LeVeque, by James Rice

Editor's Note: We don't often put obit information in the Fifth Wheel, but we're making an exception this time. Warren LeVeque passed away this month. He was one of the greats who kept the candle lit for the Corvair hobby during the dark days when Corvairs were a dime a dozen. And he did it by racing them. The following is a eulogy for Warren, written by James Rice.

My friend of several decades Warren LeVeque has departed this life as we know it, and has entered eternal rest with his Savior. He will be missed by us all.

I first met Warren and Sharon at Indianapolis Raceway part in 1978. I bummed a ride to the WOR Games, to watch the Yenko Stinger Challenge sponsored by Jim Schardt. Over the following years, we met at various Corvair and SCCA races, forming a friendship. In 1997, when I was given the opportunity and responsibility to get Jim Schardt's ex-Donna Mae Mimm's Yenko Stinger to the Monterey Historic Races in California, Warren was the first person I thought of as crew. We had a good week.

He was a most interesting man. He was small in stature, but big in heart, enthusiasm and grit. He was well educated, but was a skilled trades working stiff, not given to lots of money. He once told me the overtime pay funded his racing. When it stopped, he stopped.

Watching and listening to him in a group was to be enlightened. Whenever someone would say "I wonder if we could do this to make our cars faster," he often replied "I tried that. It doesn't help. I have the parts on my wall in my shop to prove it." But he also sometimes went "Hummm." and went home to his shop. He also served

CORSA as the Chairman of the Competition Committee for many years, writing many entertaining and informative columns.

He loved to give people rides in his race cars. One of the cheap thrills in my life was at the 2007 Detroit Convention's autocross when he gave me a ride in the ex-Bill Thomas/Doug Roe EM Corvair. What a historic Corvair race car! What a ride! I think Warren built 4 racecars from scratch, and restored or re-engineered a couple more. He was an excellent machinist and fabricator, and did some very interesting work.

For all that he accomplished, I only heard him brag once. And it wasn't about his racing accomplishments, which were many. He once said he had lived more years than any male in the LeVeque family tree. He was proud of this, as he had several physical and health issues. But he persevered. But it was his health which finally kept him out of his racecars several years ago. He had an accident on the street because of his health condition, and Sharon said enough. And he listened. Good man Warren.

To his wife Sharon, children Scott, Michelle and Michael, you have our condolences and prayers. May the God of all peace comfort you. We shed tears with you.

MYSTERY ENGINE TAP

Posted by: red monza

November 27, 2020

Some engine history: At 46,593 miles, it was time to rebuild the engine in my Corvair. It was smoking which was caused by two cracked pistons and four broken piston rings. I installed new Clarks pistons, new rod bearings, new DEVES piston rings, and a minor valve job. The car ran great – for a while.

It's not unusual for me to let cars pass me while I'm running at the speed limit. Then, when there's an opening to pass them, I engage all 4 carbs. Most times, I am closer to 90 than 80 when pulling back into the slow lane. I then enjoy all the looks my Corvair gets and some thumbs up of course when the cars pass me back. So, that

(Continued on page 4)

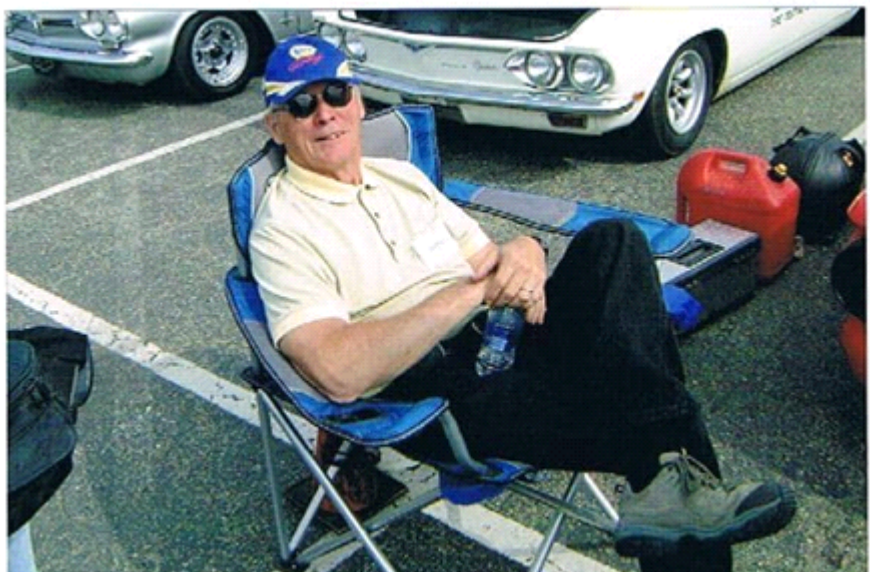

Warren's Corvair-Powered Creations



Not an ordinary Fiat 850 Spyder



Warren's "Velociraptor" formula car



Warren doing what he loved best. Autocrossing

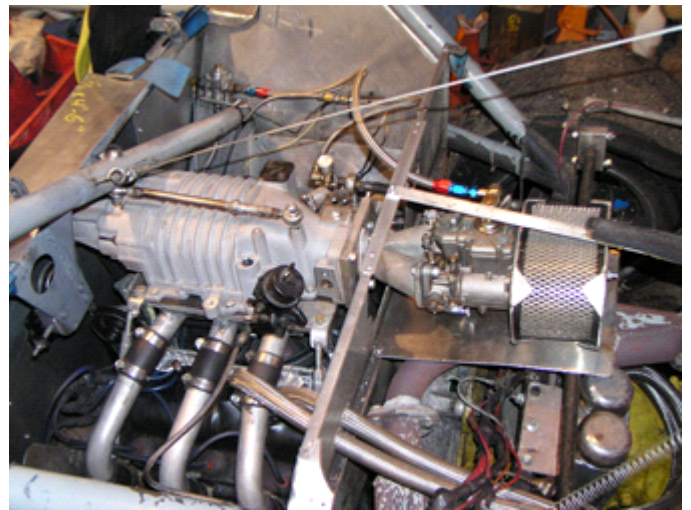

One of the Corvair engines he built



Scratch-built mid-engine tube-frame fiberglass-body



Restored Bill Thomas / Doug Roe hill climb car

(Continued from page 2)

being said...I do run the car extremely hard.

Then, at 56,600 miles, my friend with the 64 409 Impala stopped me as I was leaving and said your engine is making a tapping noise now.

I adjusted the valves several times; tapping continued. I changed some lifters; still tapping. I found two slightly bent push rods and changed them; no difference, still tapping.

I checked everything that could cause a tapping. I decided I might have a valve seat problem so I removed the engine, trans and rear end and took the heads to my machinist Nelson. He and I looked them over, heated the heads on #5 as I thought it was the one, and checked valve spring height, etc. He then said you need to go DEEPER...tapping is not here.

I then removed the pistons and jugs and took them to Nelson, who upon closer exam, found that the #5 piston top ring area had a wide gap in one area. He also found that the side of the piston was shiny and that the DEVES oil ring was in pieces. I asked him if that was my tapping noise, he said he did not think so, but he was not sure. So, I ordered new pistons and rod bearings from Clarks and new Hastings piston rings from Summit.

I then put the engine back together and installed the engine, trans, and differential. Cranked it up... after a minute...yep...tapping-tapping-tapping. So I drove the car to Nelson and let him see and hear the tapping. His advice did not change. "You gotta go deeper".

I removed the drivetrain one more time. When I took the oil pan off and cleaned it, there were about 4-6 pieces of the DEVES oil ring in the bottom of the oil pan.

I took the engine completely apart, splitting the crankcase. I looked at the crank and cam. The cam had funky grooves and wear on the lobes. I took them to Nelson. He checked the crank for straightness etc. He said it looked good.

I went to see him the next day and we looked at the cam together. There was a former Corvair mechanic there also. We took the parts outside and both said, "THERE IS YOUR PROBLEM" Part of the DEVES oil ring was embedded in the cam gear and one tooth was worn badly. I ordered a new cam and gear from Clarks...fixed the leak in the differential, put everything back together and NO TAPPING... YAY!

So, from May to November 2020, my Corvair was basically garage art. Thank god, I had my trusty 1949 Fleetline to drive during this time. It never gives any problems.

Sorry for the book I wrote but I am sure it will help someone new to Corvairs or are thinking of buying DEVES piston rings.

Follow-up. A number of other Corvair guys posted similar complaints. Here's what Bob Bauer had to say about Deves rings:

I too bought a set of those Deves rings. Put them in and it immediately smoked. Badly!! Took it apart AGAIN, and found the rings were out of round, both visually and measured by the machine shop. I sent them back to the vendor, and only got my money back, no labor or gaskets. Got a set of Grant and all is good now.

CORVAIR-POWERED SUPER VEE

This little Corvair-powered Super Vee racer is for sale in nearby Lancaster, PA. It was just listed on Craig's List on 12/09/2020, so it's a fresh listing. Here is what it says:

This is a customized Super Vee chassis that has been converted to use a Corvair engine and VW transmission. I have

(Continued on page 5)



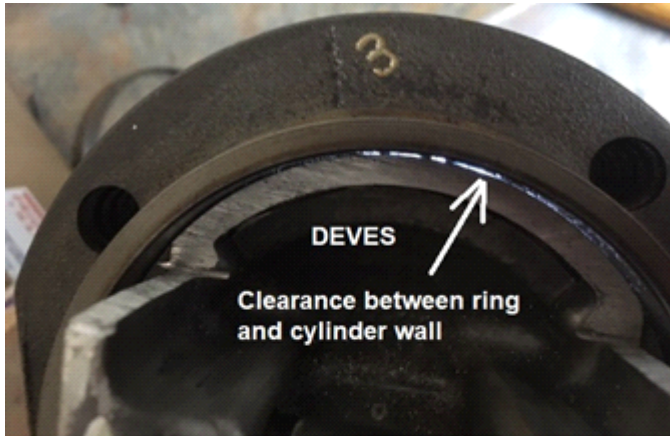
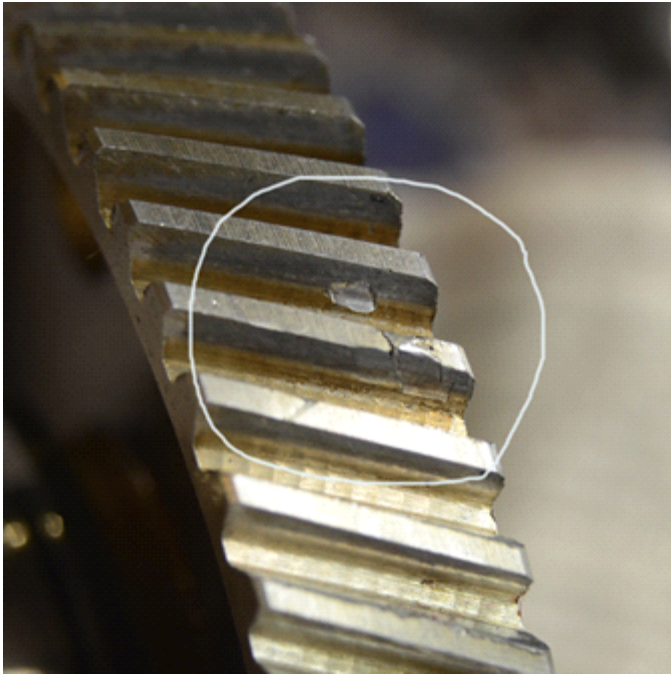

too many projects and am letting this one go. It includes everything to complete the project but new brake and clutch lines. The pedal set is a new Wildwood set up modified to fit the chassis. It also has a custom intake and new Holley spread bore installed. Suspension is wishbone front and 4 link rear with coil overs at all for corners. Could be made street legal with a brake light and turn signals. *Really? Ed.*

Blame it on Fiat! by Allan Lacki

It's an old theme. "There's nothing new under the sun". Here's another one.

The design of the original swing axle suspension for the Corvair has been attributed to Robert Schilling. But it appears that Schilling's predecessor, Maurice Olley, was involved early on in the process. He retired from GM in either 1955 or 1957, but remained on-staff as a consultant. On May 18, 1956, GM filed a patent in his name for the design.

It is Patent #2,911,052 and the title is "Independent Rear Suspension for Vehicles". You can read it online, here:

<https://patents.google.com/patent/US2911052A/en>

The drawings and description clearly depict the layout of the Corvair's swing axle suspension. It took a long time for the patent office to issue the patent. That happened on November 1959 - right after the Corvair hit the market. Coincidence?

The purpose of the patent was to lay claim for an improved swing axle suspension design. And in the text of the patent, Olley pointed-out that the typical swing axle suspension "possesses certain inherent disadvantages which have thus far prevented widespread acceptance. In particular, the ordinary swing axle, under severe lateral forces produced by cornering, tends to lift the rear end of the vehicle, so that both wheels assume severe positive camber positions to such an extent that the vehicle not only "oversteers" but actually tends to roll over."

Back in the '60s, the product liability attorneys had a field day with those words in litigating cases against the Corvair. Improved or not, the Corvair had a swing axle suspension, and that was that! It didn't help that, just a few years earlier, in 1953, Mr. Olley wrote a technical paper, "European Post-war Cars," that contained a sharp critique of rear-engine automobiles with swing-axle suspension systems.

By the way, the geometry of the Corvair swing axle suspension was a near copy of that used in the Fiat 600 introduced to the market in Italy in 1955. Like the Corvair, the Fiat's swing axles were located by semi-trailing arms to improve

(Continued on page 6)

(Continued from page 5)

the handling. Maybe Mr. Olley wasn't so creative after all.

Here is a diagram showing the one of the semi-trailing arms on the Fiat 600. The layout enabled dynamic toe changes throughout the suspension's range of motion, just like the swing-axle Corvair. The spread between the attachment points is wider, but the basic geometry is the same.

This is not to say the Corvair swing axle suspension was an exact copy of the Fiat's. Obviously, the dimensions are much different.

There is another difference, too. You may recall that the Corvair uses a spherical wheel bearing at the hub. It's purpose - aside from acting as a wheel bearing - is to compensate for the slight misalignment between the trailing arm and axle shaft that occurs as the suspension goes through its motions. Fiat attacked this problem in a different way. The Fiat design used a captive flexible coupler to attach the axle shaft to the wheel hub.

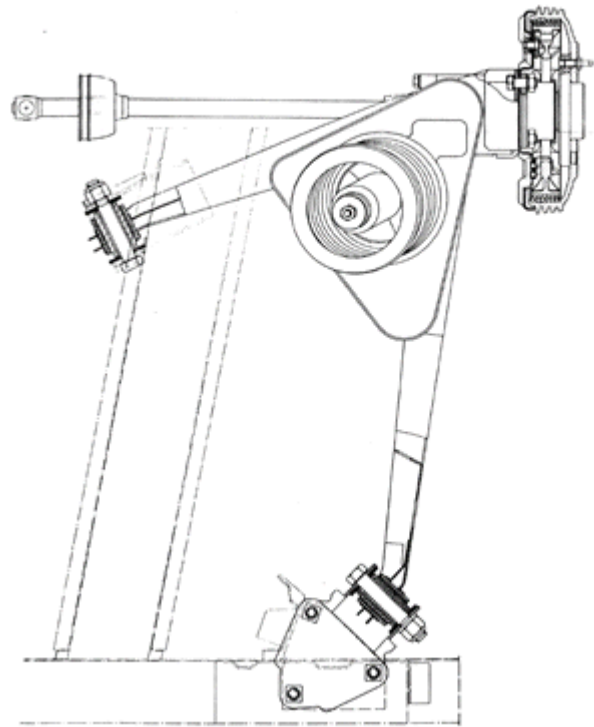
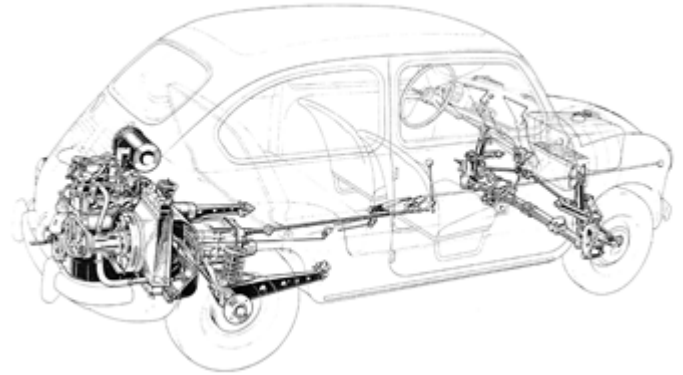

Nov. 3, 1959
M. OLLEY
2,911,052
INDEPENDENT REAR SUSPENSION FOR VEHICLES
Filed May 18, 1956
3 Sheets-Sheet 3

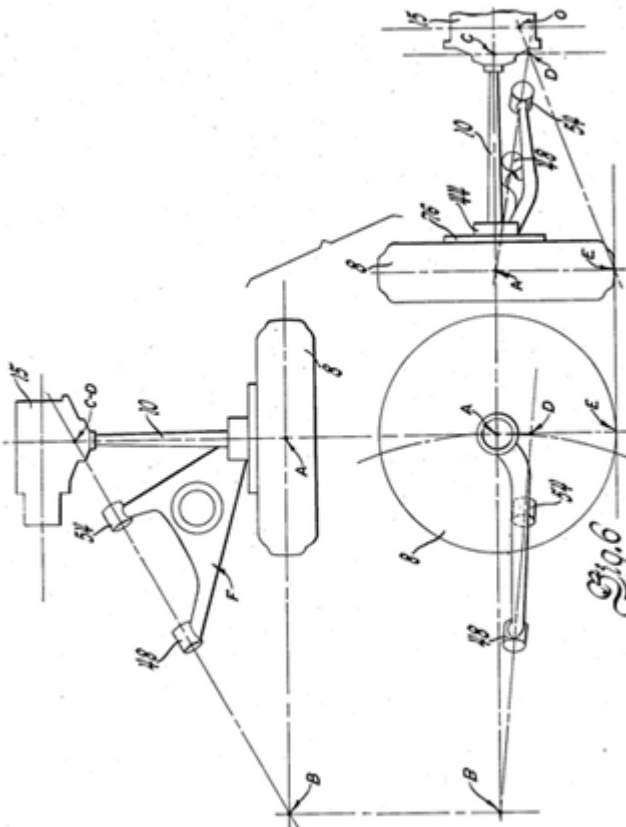

INVENTOR.
Maurice Olley
BY
Paul J. Patrick
ATTORNEY.

Top: See-through drawing of the Fiat 600 sedan.

Above: A diagram from of the Fiat 600 swing axle suspension with semi-trailing arms. This drawing is from the Fiat 600-600D Sedan and Multipla Shop Manual, printed in Italy by the Fiat Service Department.

Left: A page from Maurice Olley's 1956 patent showing the swing axle suspension with semi-trailing arms.

The Fiat went in production in 1955, before GM filed the patent for Mr. Olley.

Classified Ads



For Sale: New Parts: Brakes hoses, air filters, oil filters, tune-up parts, brake shoes, shocks, tail light lenses, gaskets, plugs, cables, choke pull offs, electrical switches, gas filters, caps, backup switches, suspension parts, engine bearings, valves, emblems, exhaust, turbo parts, patch panels, early bezels, head studs, 140 exhaust extractors, Y pipes, mufflers, fuzzies, clutch cables, lower bracket, heim joints, models, magazines, CORSA magazines, Hot Wheels, Racing Champions cars and much, much more. Contact Larry for pricing. **Used Parts:** Too many to list. Larry Asheuer Call 267-994-1569 or email: a-lcorvair@msn.com

More information and photos of the following car can be seen at Bob Marlow's website, The Garage Key - Corvairs For Sale in and around New Jersey. Here is the address: <https://garagekey.blogspot.com/>

For Sale: 1966 Monza Convertible. "Oscar" is a 1966 Monza convertible offered for sale near Mount Olive, New Jersey, with an asking price of just \$1,950. 95-hp, Powerglide, manual top. Has been parked for the past three years and is in need of TLC. The engine turns freely but is not running at present and no attempt has been made to start it. Contact the seller Larry Ashley at this email address: larryashley327@gmail.com

Many other Corvairs are available for sale at Bob's website.



1961 FORD
1960 FORD
1959 FORD
1958 FORD & Thunderbird
1957 FORD
49-61 FORD

STAINLESS STEEL TUBULAR TYPE CUSTOM GRILLES

For 55-61 CHEV, 1959 PONTIAC
60-61 CORVAIR 1958 T-BIRD
58-61 CORVETTE 1961 FALCON
49-61 FORD

Reg. \$39.95
NOW... \$16.95 Each

Give the front end of your car an entirely new, more beautiful look. Add sparkling, streamlined beauty. Grills are custom tailored and contoured to harmonize with chrome trim, blend in perfectly with body lines. Tubes curve sharply back at each end to blend into grill openings. Grills are complete with necessary mounting brackets, bolts and are already assembled. Easy to install — no alterations, cutting or welding necessary. Perfect fit guaranteed. **GUARANTEED RUSTPROOF.** Dealer quality—however big diameter, 18 gauge heavy stainless steel tubing. Tubes used in these grills are not solid but 1/2 of a full tube, open in back. Brackets have welded studs that match original grill mounting holes. No alterations required.

JC WHITNEY CO. USE THIS HANDY ORDER FORM
1917 (H-210A) Archer Ave., Chicago 16, Ill.

I enclose check or money order for \$16.95 to cover payment in full (or 25% if C.O.D.). Please do not send currency or stamps. If C.O.D. order, enclose 25% deposit, pay balance upon delivery.

Name _____
Address _____
City _____ Zone _____ State _____
My car is a _____ Year _____

NOTE: Be sure to give Make and Model of car when ordering.

1961 CHEVROLET
1960 CHEVROLET
1959 CHEVROLET
1958 CHEVROLET
55-57 CHEVROLET
60-61 CORVAIR

Clark's Corvair Parts®

Our catalog lists over 15,000 parts for your Corvair. We carry engine parts, body panels, upholstery and much more! There are 1,000's of reproduced items available, pages of technical information and lots of other helpful hints.

Clark's Corvair Parts® 400 Mohawk Trail, Shelburne Falls, MA 01370
(413)625-9776 www.corvair.com email: clarks@corvair.com



Clark's supports LVCC by donating gifts every year for our door prizes at Das Awkscht Fescht.

1971 Corvair Crossword Puzzle

This crossword puzzle was designed by noted Corvair historian David Newell many years ago. It was published in the July 1971 issue of the CORSA Windmill magazine. Some of the “clues” on the opposite page have been edited to include the answers because the questions are so arcane. For example, we wouldn’t expect you young ’uns to remember the movie “Ryan’s Daughter”.

1		2	3	4	5		6	7		8	9	10	11	12		13
		14					15									
16			17							18						
		19					20	21	22					23	24	
25	26					27	28						29			
30									31		32		33			
				34	35				36					37		38
39	40			41			42						43			
	44		45		46						47	48				
49					50					51			52			
		53		54		55					56				57	
58	59				60				61	62					63	64
65				66			67	68						69		
70			71				72						73			
	74						75					76	77			78
79					80					81						
82						83							84			



ACROSS

1. Lawyer in many cases against Corvairs (Not Ralph)
6. Corvair Sebring Spyder idea car (abbr.)
8. Camber _____
14. Rant
15. Chevy flat six trade name
16. Thus
17. Thick
18. Northern sea duck. (Look it up on Google!)
19. Corvair's clutch doesn't do this
20. Corvair coolant
23. Raw metal
25. Cars handle better with their engines there
27. Famous GM suspension engineer
29. A metallic element
30. March the 15th
31. They control FC's throttle and clutch
34. _____ the Man Who Owns One
36. Beginning
37. IECO manifold type
39. _____-in
41. Catering services have one
43. Paraguay tea (Answer: mate)
44. BMW, Mercedes & Corvair have it (abbr.)
46. At a distance
47. Turbocharged model in 1962
49. Magazine that printed "Corvair" in '62 (abbr.)
50. What Monzas did at the 1963 Canadian Winter Rally
51. First note of the music scale
52. Stage of history
53. Automobile Mfg. Assn. (abbr.)
55. A woodwind instrument
56. A sound of warning
58. Corvair pickup
61. Japanese car imported by Dodge in 1970s, plural
63. A good Corvair will turn you _____
65. Japanese coin (Not yen, but _____)
66. Pronoun
67. Exhaust problem, plural
69. Deoxyribonucleic acid (abbr.)
70. Places of contest
72. A man's nickname
73. That's show _____
74. Italian GT car from the 1960s
75. Small island
76. Corvair panel truck
79. Lard and tallow
80. They made the Gremlin (abbr.)
81. Emergency brake _____
82. What prospective members get from CORSA
83. 1970s CORSA Quarterly editor (Answer: Fiore)
84. Down (abbr.)

DOWN

2. Railroad (abbr.)
3. Belonging to Ralph. Also, _____ Raiders
4. Always
5. Don _____ of Stinger fame
6. A mint Monza at \$200.00
7. Famous foreign brand of carburetor
8. Mr. Lincoln
9. Silent, as a Corvair body
10. To roam idly. Also, an abbreviation for a disorder.
11. To be in a reclining position
12. Most accidents result from driver _____
13. _____ - Hundred
16. Fitch Corvair
19. Famous foreign gauge maker
21. Mr. Balcaen's Southern California company
22. New movie, _____ Daughter (Answer: Ryan's)
24. To turn about on an axis
26. GM's Mr. Cole
28. 1961 Corvair wagon
29. Exists
32. Bachelor of Science degree (abbr.)
33. Elapsed time (abbr.)
34. They made Corvair filters
35. 1940s Bandleader Artie _____
37. Speeders are trapped with it
38. TV show producer, _____ Griffin
40. What is seen on most Corvair grills
42. What Corvairs are supposed to throw off
43. Belonging to Miss Breckinridge
45. Place for oil
48. Fur
49. 180 h.p. in this model only
51. How long was the Corvair made?
53. Eldridge Cleaver sought this in Algiers
54. Large continent
56. _____ - Lorraine
57. GT and Spyder, plural
59. It's now in some windshields
60. Belonging to something
62. Chevrolet _____ Used Cars
64. Not available (abbr.)
68. Co. that made quick shifts and oil pans for Corvairs
69. Sofa
71. Olfactory organ
73. Make by fermentation
75. Impossible Missions Force (abbr.)
77. Opposed to new
78. Horsepower rating adopted in 1972. SAE _____
79. Jensen _____ 4WD sports car
81. Prefix meaning repeat action



Final Dues Reminder

A few of our members still haven't paid dues the current period. A few weeks ago, we sent emails to those of you who are among the missing, so you know who you are.

Our accounting year is from August 1 to July 31. Most LVCC members pay their annual dues either at Das Awkscht Fescht or during one of our normal monthly meetings. But Das Awkscht Fescht was cancelled this year and, due to COVID, we haven't resumed our normal meetings.

So, to pay-up, we need to mail our dues directly to Dick Weidner, our Secretary / Treasurer. His postal address is 2304 Main Street, PA 18067. The price of LVCC membership remains very reasonable at \$15 per year, and if you are also a member of the Corvair Society of America, the rate drops even lower to \$10.

You're on our list!

Our list shows that the following members haven't yet paid up.

- Larry Asheuer
- John Egerton
- Jason Hewitt
- Larry L. Lewis
- Chuck Mason
- Scott Oberholtzer
- Dale Parkhurst
- Kyle Regan
- Paul Shade
- Joe Turner
- Timothy Turner
- Bob Weideman

So, what happens if you don't pay your dues? It's simple. You'll no longer enjoy the honors and benefits accorded to LVCC membership. (Word stolen from the *Christmas Story* movie). In other words, you'll stop receiving copies of our wonderful monthly newsletter.

Can you rejoin? Of course! Simply pay the dues. We'll keep your contact information on-file for when you return.

This Month's Puzzle Solution

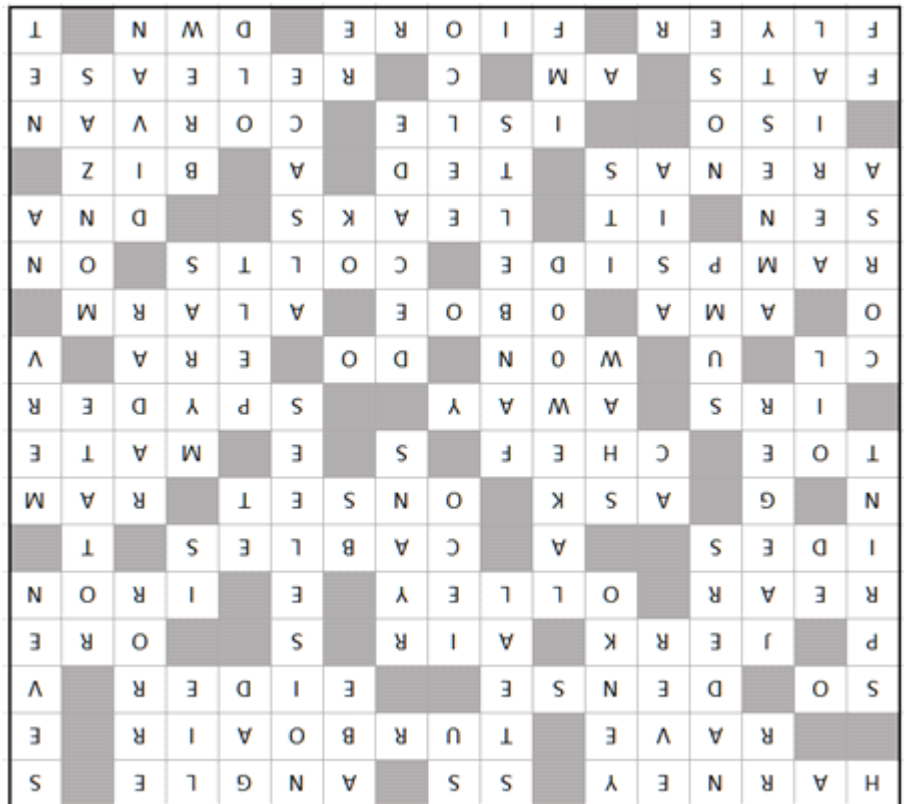

LVCC Officers

- President: Dennis Stamm Phone: (610) 926-4723 Email: dmstamm@comcast.net
- Vice Pres: Fred Scherzer Phone: (484) 948-5142 Email: jukeboxman44@gmail.com
- Secretary / Treasurer: Richard Weidner. Phone: (610) 502-1414 Email: anythingvair@yahoo.com,
- Newsletter & Website Editor: Allan Lacki. Phone: (610) 927-1583 Email: redbat01@verizon.net

