



CORVANATICS GROUP

CORVAN ANTICS

VOLUME 3

NUMBER 4

WINTER 1975

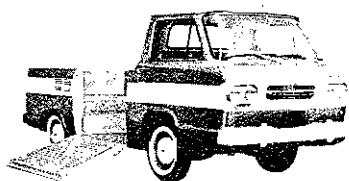

RAMPSIDE/LOADSIDE



GREENBRIER SPORTSWAGON

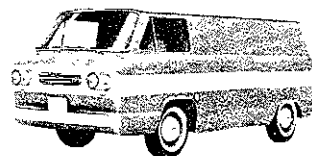

CORVAN

Illustrations by Chevrolet Motor Division

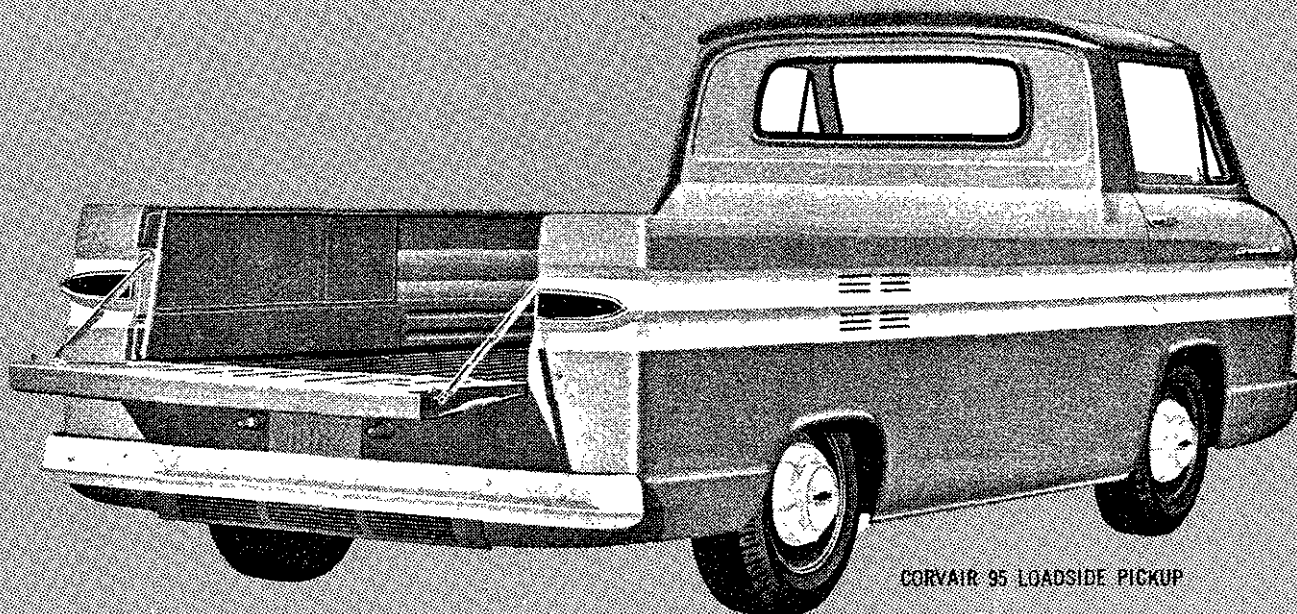

CORVAIRE 95 LOADSIDE PICKUP

CONTENTS

Officers, Staff and Statistics ... page 26	Loadside from Texas 30
President's Corner 26	Roster and Dues 30
Secretary-Treasurer's Report 26	Scale Models 31
Loadside (Front Cover) 26	Backfire 31
Tech Topics 27	From The Editor's Desk 31
Back Issues 27	Classified 31,32
Membership Roster 28,29	

OFFICERS, STAFF AND STATISTICS

Founder & President: Ken T. Wilhite Jr., 3654 Green Ash Court, Indianapolis, IN 46222
 Secretary-Treasurer: Cecil C. Miller Jr., 2086 S. Hawthorne Rd., Winston-Salem, NC 27103
 Editor: Nico H. DeJong, 3422 Veralta Drive, Cedar Falls, IA 50613
 Technical Editor: Russ J. Long, 6798 North Maple, Fresno, CA 93710
 Contributing Editor: Stella Piest, 9342 Gilbert Street, Anaheim, CA 92804
 Registered Agent: Pete P. Smith, 1944 Evergreen Road, Homewood, IL 60430
 Membership: 108
 Newsletters: Spring, Summer, Fall and Winter quarterlies
 Deadlines: General copy & ads (mail to editor) - 1 March, June, Sept. & Dec.
 Dues & Subscription: \$5-/year; mail to secretary-treasurer
 Back Issues (14): \$1- each; complete set 25% off; order from editor
 Checks & Money Orders: Make payable to CORVANATICS

PRESIDENT'S CORNER

I'll start this column by welcoming all the new members who have joined in the past few months. Judging from the requests for applications and letters I've received, our membership has increased substantially. I might also mention that if you try to find new members, it will benefit the club greatly. That's all for now. See you later.

KEN

SECRETARY-TREASURER'S REPORT

As the membership will recall, at my appointment to this position in July '75, CORVANATICS was "in the red," financially. I am pleased to report that the balance in our treasury now stands at \$219.75. The old-member up-date in September '75 was disappointing from the standpoint of updated forms returned. Of the 74 members polled, only 25 replied. Therefore, many older members had to be dropped because of unpaid dues. However, we continue to be pleased with the growth in new membership since our last newsletter - 39 - making a grand total of 108 members. I would like for club members to send me photos of their vans and trucks, to be included in a planned display at the 1976 CORSA National Convention in Philadelphia. CORRECTION: Last line of my Fall '75 report should read "... we can make CORVANATICS a Super Club for all to enjoy!"

CECIL

CORVAIR 95 LOADSIDE PICKUP (FRONT COVER)

Highlighting the Loadside model in this edition, it was identical to the "Rampside", except for the absence of a rampgate in the R.H. pickup box side. Corvaire connoisseur Dave Newell writes us, "Chevy treated the Loadside as a 'me too' item with the Rampside in '61 and '62 literature." Following are some statistics:

Model: R 1244	1961 Production: 2475	Curb Weight: 2705 lbs.
Wheelbase: 95 inch	1962 " : 369	Payload Capacity: ... 1895 "
Cubic Capacity: 175 cu.ft.	Total Production: 2849	Gross Vehicle Weight: 4600 lbs.

Ref.: '61 Corvaire Shop Manual, pages 1-8, 10-72,73,74; CORSA COMMUNIQUE July '73, p.5
 Front Cover Photo: Courtesy Mark Ellis, Radnor, PA. Thanks very much, Mark!

TECH TOPICS by Russ Long, Technical Editor... The mail has piled up with questions, so let me see how many I can answer for you this time:

(1) Ed Hayden of Walnut Creek, CA, asks three questions: "What kind of aftermarket WHEELS can be used without butchering the wheel wells; what is the largest TIRE that can be used; and what must be done to a passenger car block to move the OIL FILLER to the standard van location?"

Either 14 or 15x7 inch are as large as I've seen mounted without any fender flaring. The critical thing here is that the offset of the WHEEL be towards the center of the vehicle (negative) in order to clear the rear fenders. "Deep Dish" will not clear unless you are a proficient bodyman.

The largest diameter TIRE I have seen has been a CR78x15 on a 6" Chevy wagon wheel. The fattest cross-section I have seen is GR60x15 BFG Radial T/A's on 8" rims with flared fenders. The most comfortable fitting tire I've seen has been a GR70x14 on 6" Chevelle wagon rims. This combo did not require any wheel well modifications at all.

The FC and 61-62 station wagon blocks have a cast-in boss on the RH side of the block for the OIL FILLING APPARATUS. Some 65 Turbo blocks also had this boss cast in. In order to convert a passenger block, you would need to have an FC block as a guide, and access to a good heliarc welder and machinist - or find an FC block. Any FC block can be converted to the 164-inch specs with some careful machine work to allow for connecting rod clearance. Bill Fisher's book has some detailed drawings on this, and any competent machinist could do the work. Otherwise, you might try putting a piano hinge on the forward edge of the engine lid and make do.

(2) New member James Emmi of North Syracuse, NY, asks: "... information on installing a TRANSVERSE LEAF SPRING on my van..." This is indeed a good modification if you plan on carrying a considerable amount of weight in your van. It has no effect on the handling; it did not on the 64 sedans, as is popularly believed. To make this modification, you will need the following parts from a 64 sedan: rear axle case, leaf spring and attaching hardware, rear control arms (for study only, as FC arms are slightly longer) and all the various nuts and bolts involved. Some parts are still available from Chevy, although the attaching bracket to the bottom of the transaxle has been discontinued; so you will need a good used one. The axle case is required because the 64's have a boss cast-in as the upper support for the spring, and the control arms have a plate welded to them for the attaching hardware on the ends. I've been contemplating this mod myself, and it is still in the planning stages, although mine will be easier since my 64 has the provisions for the spring already there, except for the control arms. The above is as much information as I have to go on, so maybe someone who has completed such an installation can help us both out...

For lack of more space I'll have to keep you in suspense and give you my answers to other questions in the next edition.

RUSS

BACK ISSUES... By popular request, here's a listing of all CORVAN ANTICS newsletters, published till now. Ordering instructions and prices are always at the end of paragraph 2 of the inside front cover.

Year:	Volume:	No.:	Dated:	Year:	Vol.:	No.:	Dated:	Year:	Vol.:	No.:	Dated:
1972	I	1	Sept. 72	1974	II	1	Jul./Aug. 73	1975	III	1	Spring 75
		2	Nov. 72			2	Feb. 74			2	Summer 75
		3	" 72			3	June 74			3	Fall 75
		4	Dec. 72			4	Sept. 74			4	Winter 75
1973		5	Jan. 73			5	Dec. 74				
		6	Feb./Mar. 73								

You may also want to consider ordering attractive binders for your favorite newsletter at \$2- each from fellow-Corvanatic and CORSA secretary Mark Ellis, 145 Ivywood, Radnor, PA 19087. One of these will hold and protect all 1972 through 1974 CORVAN ANTICS editions - without the need for punching holes. With these binders in mind, page numbering has been made continuous, as of the Spring '75 edition, for your convenience. Some day we also hope to have an index available for each binder for turning your bound volumes into handy quick-reference guides. Any volunteers?

CORVANATICS MEMBERSHIP ROSTER*

Name:	Address:	Unit(s)**:
Alexander, Terry V.	221 Jackson Denver CO 80206	65G
Anderson, Larry & Nancy	3907 Sharondale Dr. Hamberg NJ 14075	64G
Auclair, Duncan	2975 W. 12th Avenue Vancouver BC V6K2R2	62C
Baker, Richard V.	1750 Burke N.E. Grand Rapids MI 49505	63G
Bender, Robert E.	767 Pelican Way El Cajon CA 92020	63C
Black, David A.	33 E.Cleveland St. Greenfield MA 01301	63C
Brenneman, Wally	Route #1 Kalona IA 52247	64G
Cann, Charles	511 W.2nd Street Oil City PA 16301	61G,62R
Cassie, Alan G.	21 Winslow Road Chelmsford MA 01824	64G
Chilton, Maurice	5351 Charlsie Court New Orleans LA 70114	63G
Clarke, Thomas B.	P.O. Box 64 Canutillo TX 79835	..C,62L,64G
Cole, Lyle D.	Star Rt., Box 581 Cohoe AK 99570	63G
Craig, Jim	7731 Peacock Drive San Diego CA 92123	63C
Cremers, David	129 Audubon Drive Pullman WA 99163	62G
Dahlgren Jr., William A.	415 Hazlewood Lane Glenview IL 60025	63G
Davis, Donald A.	3366S 600E Marion IN 46952	63C
DeJong, Nico H.	3422 Veralta Drive Cedar Falls IA 50613	61G,62G
Demeter Jr. Michael E.	11446 Karyl Lane Cincinnati OH 45240	
Eaton, Byron	8806 Balcones Cl.Dr. Austin TX 78759	64R
Edmonds, Richard	629 UnionLanding Cinnaminson NJ 08077	65G
Ellis, Mark	145 Ivywood Lane Radnor PA 19087	
Emmi, James A.	7365 Rosewood Circle North Syracuse NY 13212	63C
Fabre, Fernand	15788 Rose Fontana CA 92335	
Fahey, Tom J.	103 Hemlock Rd., RD7 Mechanicsburg PA 17055	
Farlin, Dale R.	4619 Burchfield Lansing MI 48910	61G
Fearonce, Nate	1033 Pointview St. Los Angeles CA 90035	61R
Fitzpatrick, Terry S.	Rt.#1, Box 28A Elmwood TN 38560	61G
Fleener, Roger O.	8819 So. Main Road Rockford IL 61102	61R,63R,64G,64R
Gaida, Kurt E.	129 Green Acres Clearwater FL 33515	63G
Garrison, John B.	13123 Main Road Akron NY 14001	61R,64G
Geraci, James L.	5835 Cheswood Houston TX 77017	..C
Goetz, Valerie	421 University St. West Lafayette IN 47906	63G
Goff, William L.	R.R.#2 Kendalville IN 46755	61C
Goode, William P.	3811 Pyke Drive Dallas TX 75233	63C
Gridley, Edwin & Betty	R.R.#2, Box 158 Franklin IN 46131	2..G,..L,2..R
Grille Jr., Alvin W.	660 Newman Avenue Jefferson LA 70121	2..C,2..G,2..R
Guion III, Louis I.	11923 Quincy Lane Dallas TX 75230	61G
Halvorson, Clarence R.	1724 Dupont Drive Lemon Grove CA 92045	62C
Hansen, Dean	9825 Oso Street Chatsworth CA 91311	63C,2..R
Harp, Rush	B69 Yankee Tn. Pond Bearsville NY 12409	..G,..R
Hayden, Ed	1369 Milton Avenue Walnut Creek CA 94596	61L or 61R
Hollertz, Mont	Box 183 Minden NB 68959	
Houghtaling, Lee	477 Sunshine Dr. A-1 Coconut Creek FL 33966	61G
Howell, Jim L.	3533 Rothmoor Drive Knoxville TN 37918	
Howell Jr., John E.	Rt.1, Old B'milk Rd. Lenoir City TN 37771	61R
Hoyt, John F.	Box 457 Granby CT 06035	63C
Jones, K. Mason	11432 Cashmere Los Angeles CA 90049	
Keast, Larry G.	9314 Livernois Houston TX 77055	62G
Kerkhoff, John G.	13268 Glamis Street Pacoima CA 91331	62R,65G
Kugler, Dennis D.	7257 Cosner Drive Dayton OH 45424	63R
Lee, MSgt. Edward G.	4258 Valleyfield San Antonio TX 78222	61C,63R
Leece, James L.	4616 Burchfield Lansing MI 48910	
Leonelly, Earl A.	4149 Main Street Central Valley CA 96019	61G,63G
Lienhard, Garry D.	P.O.Box 451 Salem OR 97308	62G

CORVANATICS MEMBERSHIP ROSTER (CONT'D)*

Loftin Jr., W.R.	2412 Landmark Drive Raleigh NC 27607	64R
Long, Russ J.	6798 North Maple Fresno CA 93710	64C
Malcolm, Douglas H.	215 N.Ocean Avenue Patchogue NY 11772	61L
Malmstrom, Richard W.	18 Bellevue Avenue Longmeadow MA 01106	61R,62C
Markey, SSgt. Gabby	PSC#1, Box 1462, APO Seattle WA 98742	62R,64C
Marshall, Eugene C.	4039 Tartan Houston TX 77025	65G
Martin, Dick	3661 Antiem Street San Diego CA 92111	62C,62G,62R
Martin, Keith	1890 N.36th Street Galesburg MI 49053	63R
Matthews, Donald L.	720 Stendhal Lane San Jose CA 95129	64G
McIntosh, C. Vern	1814 B.Wildbrook Ct. Concord CA 94521	64C
McKeel, Michael B.	23281 Rosewood Oak Park MI 48237	64G,65G
McKeown, Anthony F.	HSL-35,NAS,N.Island San Diego CA 95135	64G
Miller Jr., Cecil C.	2086 S.Hawthorne Rd. Winston-Salem NC 27103	63R,64C,64G
Miller, Donald V.	Rt.#5, Box 332 Lebanon PA 17042	64G
Misfeldt, Richard	3208 Teton Drive,NW Huntsville AL 35810	
Moore Jr., Walter E.	310 Altaview Drive Monroeville PA 15146	61R,64G,64R
Morris, H.V.	3700 Hycliff Avenue Louisville KY 40207	64G
Murphy, Thomas P.	90 Spring Street Wilkes-Barre PA 18702	64G
Nance, Charles E.	5 Bryce Court Indianapolis IN 46222	61L,2x61R
Newell, Dave	1481 Hamrick Lane Hayward CA 94544	62G
Niblett, M.A.	6354 Jeff Street San Diego CA 92115	61G,64G
Payne, Jack P.	Box 167 Middleton TN 38052	62G,64G
Piest, Lloyd & Stella	9342 Gilbert Street Anaheim CA 92804	63C,63G
Prichard, William C.	Box 843, Highway #9 Black Mountain NC 28711	64R
Reihing, Martin O.	3940 Willys Parkway Toledo OH 43612	62G,65G
Rice, Robert E.	5955 Schuyler Street San Diego CA 92139	61C
Richardson, Gordon	4 Ilfracombe Cr. Scarborough Ont. M1R3R8	61C
Rockwell Jr.MD,Dr.J.E.	620 W.North 2nd St. Grangeville ID 83530	65G
Shepard, Spencer	24 Willow Lane Scotia NY 12302	64G
Shields, Mark J.	Box 387 Toccoa Falls GA 30577	62R
Shockley, Sam W.	11206 West 50th Shawnee KS 66203	..G
Shriber, Jack L.	1642½ Andrews PPlace Williamsport PA 17701	62R
Silvey, Thomas C.	Box 68 McCordsville IN 46055	64R
Simmons, Michael L.	2 W.Casino Rd.No.207 Everett WA 98204	61C
Skony, Peter M.	3611 North Avers Chicago IL 60618	62C,64G
Smathers,Dave & Scotty	7022 Holiday Road N. Jacksonville FL 32216	
Smith, Chris	1125 Gill Hall Road Jefferson Hills PA 15025	64R
Smith, Ken	RR#1 Baldwin LA 70514	61C
Smith III, Lockhart J.	72 Cleveland Avenue Saugus MA 01906	63G
Smith, Peter P.	1944 Evergreen Road Homewood IL 60430	..G,..R
Smith DMD, Richard L.	8402 41st Street W. Tacoma WA 98466	63G,64G
Smith, Robert J.	36 Laurel Drive Cornelia GA 30531	64R
Spillman, Harvey L.	4212 Ebert Rd.,Rt.#4 Winston-Salem NC 27107	64G
Sundheim, Ed	1373 Ellison Avenue Bronx NY 10461	64G
Sutherland, Dave E.	5003 University Ave. Cedar Falls IA 50613	62G
Tausend, Wes	1427 Michigan Avenue Bismarck ND 58501	63C
Terranova, Gerry J.	2805 Oak Cliff Lane Arlington TX 76012	63G
Tulley, J.H.	80 Dow Avenue Mineola NY 11501	61G
Walker, Thomas L.	6060 North 25th Road Arlington VA 22207	63G
Wall, Lon	200 S.Grant, Box 142 Newberg OR 97132	61C,62R
Weitzel, Edward D.	4105 S.College Ave. Tempe AZ 85282	..C,2..R
Wells, George E.	3466 Marathon Drive Columbus GA 31903	63G
Wilhité Jr., Ken T.	3654 Green Ash Court Indianapolis IN 46222	
Wisby, Capt. Tom M	807 South Jamestown Tulsa OK 74112	64C

* Paid-up at least till 1 Jan.'76. ** C=Corvan, G=Greenbrier, L=Loadside, R=Rampside

LOADSIDE FROM TEXAS by Tom Clarke

It all began in August, when I was climbing my way up Mount Evans, Colorado. Cruising along on the world's highest paved "road" (if you want to call it that), I suddenly saw this Greenbrier camper, taking a break three fourth of the way up the mountain. That's how I met your friendly editor and family in their "Flying Dutchman". We were soon talking Corvairs, as most "Vair" owners do. Before long I found myself joining CORVANATICS at 14260 feet, and Nico asked me to do an article on my Loadside.

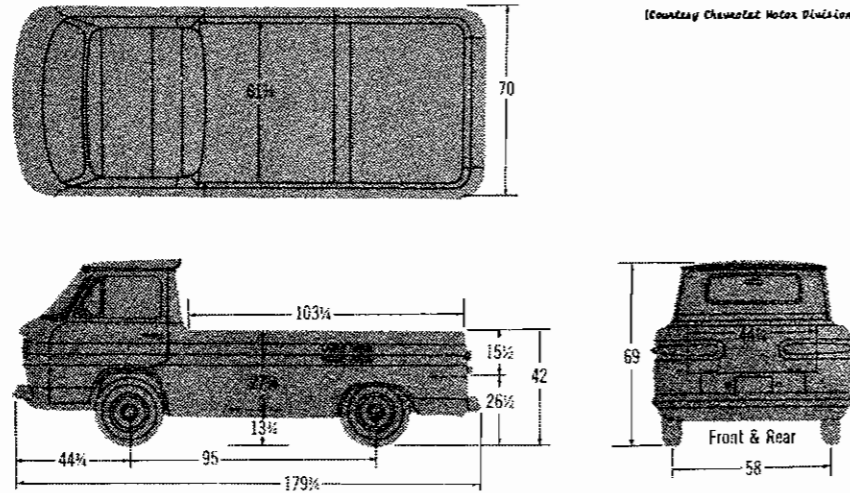

The pickup is the second member of my Corvair family of four, which includes a Greenbrier, a Corvan and a Monza. I found the Loadside behind the U.S. Post Office of Canutillo, Texas, where it had been used as a doghouse, among other things. My Corvan had a bad rear axle, so I got the Loadside for parts. Well, Nico almost got sick when I told him that I had almost taken it to a steel mill for lack of space and because I had all the parts I needed by then. After pointing out that Loadside's are the "white elephants" in the Corvair family of 95-inch-wheelbase pickups, vans, and wagons (only 369 units of my '62 model were made), he convinced me to put it back into running order. So - that's what I'm doing.

I plan to keep it stock, except for a 110-hp engine and automatic transmission. The body is all there, and the unit runs, but it needs a good overhaul. Maybe I'll report to you again when everything is back in good working order.

Sorry I couldn't get any pictures for this edition. The owner of the place where the Loadside is stored for the time being is on a long vacation, and I hope the factory drawings of top, side, and rear views with dimensions will do as an acceptable substitute. I'm looking forward to reading about the experiences of others in future CORVAN ANTICS newsletters.

TOM
Canutillo, TX

ROSTER AND DUES... The membership roster on pages 28 and 29 is the result of the combined efforts of your secretary-treasurer and editor. Please report any inaccuracies to Cecil. We're also asking everyone to pay particular attention to the last line of your mailing label from now on. As of the Fall '75 edition we've been showing your EXPIRATION DATE (day, month & year) which we "calculate" by simply taking the date on your latest \$5- check or money order and adding 1 year, or adding 2 years to the date on your latest \$10- check or money order. If your dues are due, or almost due, your E.D. is followed by the line "SUBSCRIPTION RENEWAL INVITED". This method not only (1) eliminates the need for sending out separate renewal notices, but also (2) keeps us from sending newsletters to folks who are not paying their dues - thus (3) helps keep your club's treasury in the black. By comparing your E.D. with your latest date of payment, you can (4) check to see if our records are correct, and - finally, as a practice followed by most periodicals, it will (5) help you keep your CORVANATICS membership in force, which will keep your name on the mailing list for this newsletter.

SCALE MODELS... With reference to the news item on Corvan scale models on page 23 of the Fall Edition, we received a friendly reply from the Amway Corporation, in response to our inquiry. There are none left at their headquarters, but they promised to check with their distributors.

BACKFIRE... Quite a few of you have written, and we appreciate the response - keep those cards and letters coming! Unfortunately we again lack the space to answer you in this column. But please be patient; we will react to your needs one way or another. As Ken explained in his "President's Corner" of the '75 Fall Edition, sending your inquiries to the right people will help speed up action. We will publish your stories and articles in future editions, providing you added a good illustration (black-&-white photo, sketch, drawing, diagram, or cartoon). Thanks again for writing!

FROM THE EDITOR'S DESK... I apologize for this edition reaching you late - caused by much overtime, a legal problem in connection with the passing away of my parents, income tax filing, and overdue columns. I'll try to get back on schedule. CORVANATICS owes secretary-treasurer Cecil Miller, capably assisted by his wife Pat, a big Vair hug for putting our treasury back in the black in less than half a year after he accepted that position - despite much regular-job travel. If at all possible, plan to attend your annual CORSA convention, to be held on 15-18 July in Philadelphia this year. It promises to be one of the best ever! The impressive number of new members is very encouraging. But we mustn't rest on our laurels. Unless we raise the dues, we'll need more members (1) to meet price hikes, such as the increase in postage and printing rates, and (2) to maintain and improve services to members. I believe it can be done, if we all try a little harder. We finally broke the 100-Corvanatics barrier, and you may wonder when we'll be hitting the 1000-mark. Actually that day doesn't need to be as far ahead as you might think. A little simple grade-school arithmetic shows that if, as of now, every member will start finding only one new member per year, we'll have 1000 members in less than THREE years from now! So what do you say we resolve to do just that for the next three years? Happy Bicentennial!

CLASSIFIED... Free to CORVANATICS members. Non-members: \$3-/5-line ad. Approved furnished flier inserts free up to 13¢ postage limit. Commercial rates upon request.

FOR SALE: 64 GREENBRIER, 95hp. 4-spd., by orig'l owner. Always garaged, very little rust. Accessories include Junior West Cst. side mirrors, front arm rests, RH side visor, AM radio, windshield washer, 3rd seat, front entrance step pads, front seat belts, camping screens, radial tires, new orig'l hubcaps. No foot ever touched carpet-covered front mat; ash tray never dis-graced. 140000 miles. Extra windshield, 3 spare carbs & other parts; record of all mech'l work. Noisy transmission bearing. One broken piston (3rd time). Will sell for best offer. Tom Williams, 65 Orange Elizabethtown, PA 17022, ph.717-367-7349.

FOR SALE: 65 GREENBRIER; only 1528 units made. Red & white stripes, 3 seats, 110hp, 4-spd., orig'l owner. Nice appearance, minimal rust, excell. maintenance, engine rebuilt at 103000. Current mileage 116000.

\$1200. J.E.Rockwell, 620 W.No.2nd, Grangeville, ID 83530; ph.208-983-0560.

FOR SALE: 65 GREENBRIER, 8-dr., automatic, 95-hp. Excell. body, ARA air cond'r incomplete, being repaired. Make offer. Spare parts available. Also 65 140-hp engine with van block. R.L. Misfeldt, 3208 Teten Dr., Huntsville, AL 35810; ph. 205-852-2947.

FOR SALE: PACE 10-2 CB RECEIVER, 3-channel (7,9,20), microphone, antenna, coax., cig. lighter adapter. \$45-; K.T. Wilhite Jr., 3654 Green Ash Ct., Indianapolis, IN 46222 ph. 317-264-7729.

WANTED: REAR ACCESS DOOR, GLOVE BOX DOOR, RH SIDE ALUM. DOOR SILL PLATES for 61 CORVAN. Gordon Richardson, 4 Ilfracombe Cr., Scarborough, Ont., M1R 3R8, Canada.



(See story on page 6 of CORVAN ANTICS Spring 1975 edition)

● FEATURES ●

Sink, hand pump, 12-gal. tank; range with oven. Sleeps 4 adults. Propane lamp, 12- and 115-v. Table, benches, closet, plenty of storage. Easy access to engine. Camper jacks; opening to cab through windows. Ice box; marker lights. (Truck not for sale.)

Our unit weighs 4570 lb. with truck.

Old truckers never die... they just keep on truckin'!

FOR SALE

Corvair "95" Camper Body

Complete, ready for installation on your Rampside \$795⁰⁰

This is a very rare unit. Not many of them around. We're second owners.

JOHN C. JACKSON 2934 Vivian Lane
San Jose, Cal. 95124 - 408 377-0560

CORVAN ANTICS
Nico H. DeJong, editor
3422 Veralta Drive
Cedar Falls, IA 50613



ADDRESS CORRECTION FORM 3547 OR 3579 REQUESTED

FIRST CLASS MAIL

1.76

CORVANATICS

Formed in 1972
by and for those who still appreciate the Corvair Automobile,
particularly the Corvair "95" Series pickups, vans and wagons.

* a branch of the Corvair Society of America (CORSA), Inc.