

985359

CAR CAMPER CHILD BED INSTRUCTION SHEET

CORVAIR 95 GREENBRIER

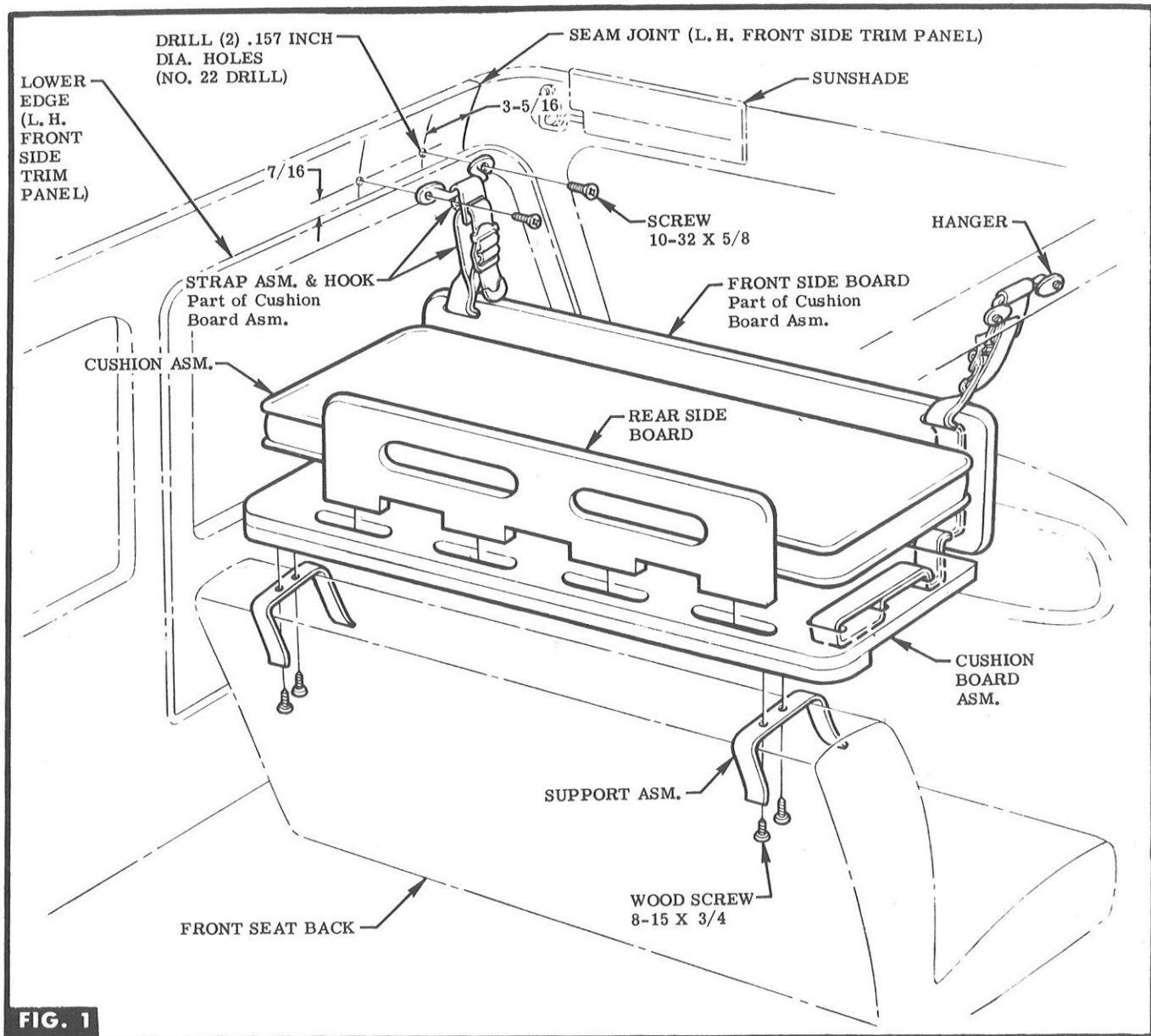

FIG. 1

STEP 1 LOCATE, CENTER PUNCH & DRILL HOLE IN L. H. & R. H. FRONT SIDE TRIM PANEL. USE STRAP HANGER AS TEMPLATE TO DRILL REMAINING HOLE. SEE FIG. 1.

STEP 2 INSTALL HANGER TO L. H. & R. H. TRIM PANEL WITH SCREWS. SEE FIG. 1.

STEP 3 LOCATE TWO HOLES IN EACH SUPPORT BY PIERCING THRU VINYL SLEEVE WITH AWL & INSTALL SUPPORTS TO CUSHION BOARD (PILOT HOLES PROVIDED) WITH SCREWS. SEE FIG. 1.

STEP 4 INSTALL CUSHION BOARD IN POSITION OVER TOP OF FRONT SEAT. SEE FIG. 1.

STEP 5 HANG HOOKS INTO HANGERS & ADJUST EACH STRAP SO THAT CUSHION BOARD IS HORIZONTAL. SEE FIG. 1.

STEP 6 PLACE CUSHION ON CUSHION BOARD & INSERT REAR SIDE BOARD INTO SLOTTED HOLES IN CUSHION BOARD. SEE FIG. 1.